

**IMMOBILIZER  
(DIAGNOSTICS)**

# Basic Diagnostic Procedure

IMMOBILIZER (DIAGNOSTICS)

## 1. Basic Diagnostic Procedure

### A: PROCEDURE

	Step	Check	Yes	No
1	<b>CHECK SECURITY INDICATOR LIGHT.</b> 1) Turn the ignition switch to "OFF" or "ACC". 2) Wait at least 60 seconds.	Does the security indicator light blink?	Go to step 2.	Check the security indicator light circuit. <Ref. to IM(diag)-10, CHECK SECURITY INDICATOR LIGHT CIRCUIT, INSPECTION, Diagnostics Chart for Security Indicator Light.>
2	<b>CHECK KEY SWITCH.</b> Remove the key from ignition switch.	Does the security indicator light blink within 1 second after removing the key?	Go to step 3.	Check the key switch circuit. <Ref. to IM(diag)-12, CHECK KEY SWITCH CIRCUIT, INSPECTION, Diagnostics Chart for Security Indicator Light.>
3	<b>CHECK SECURITY INDICATOR LIGHT.</b> Turn the ignition switch to ON.	Does the security indicator light go off?	Go to step 5.	Go to step 4.
4	<b>CHECK ENGINE START.</b> Turn the ignition switch to START.	Does the starter operate?	Check the LAN communication circuit. <Ref. to LAN(diag)-2, Basic Diagnostic Procedure.>	Check the DTC display (body integrated unit). Go to step 7.
5	<b>CHECK ENGINE START.</b> Turn the ignition switch to START.	Does the starter operate?	Go to step 6.	Check the LAN communication circuit. <Ref. to LAN(diag)-2, Basic Diagnostic Procedure.>
6	<b>CHECK ENGINE START.</b> Turn the ignition switch to START.	Does the engine start?	Immobilizer system is normal.	Check the DTC display (ECM). Go to step 7.
7	<b>CHECK FOR ANY OTHER DTC ON DISPLAY.</b> 1) Turn the ignition switch to OFF. 2) Connect the Subaru Select Monitor to data link connector. <Ref. to IM(diag)-7, Subaru Select Monitor.> 3) Turn the ignition switch and Subaru Select Monitor switch to ON. 4) Read DTC's on the display.	Is the DTC displayed on screen?	Go to step 8.	Repair the related parts.
8	<b>PERFORM DIAGNOSIS.</b> 1) Inspect using the "Diagnostic Procedure with Diagnostic Trouble Code (DTC)". <Ref. to IM(diag)-14, Diagnostic Procedure with Diagnostic Trouble Code (DTC).> 2) Repair the trouble cause. 3) Perform the Clear Memory Mode. 4) Read DTC's again.	Is the DTC displayed on screen?	Inspect using the "Diagnostic Procedure with Diagnostic Trouble Code (DTC)". <Ref. to IM(diag)-14, Diagnostic Procedure with Diagnostic Trouble Code (DTC).>	Finish the diagnosis.

## 2. General Description

### A: CAUTION

**CAUTION:**

- Do not use the electrical test equipment on the airbag system wiring harnesses and connector circuits.
- Be careful not to damage the airbag system wiring harness.
- While diagnostic items are being checked, do not operate radios, portable telephones, etc. which emit electromagnetic waves near or inside the vehicle.

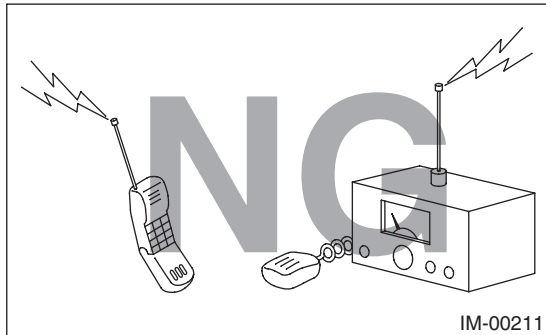

- When turning the ignition switch to ON or OFF while diagnostic items are being checked, do not allow keys with different ID codes close to the ignition switch. If the ignition key is on a key holder, remove it from the key holder before performing diagnoses.

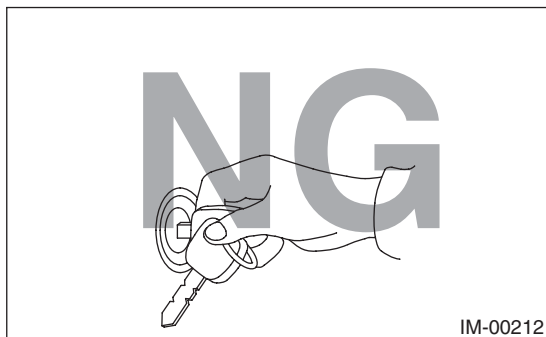

- When repeatedly turning the ignition switch to ON or OFF while diagnostic items are being checked, it should be switched in cycles of "ON" for at least 5 seconds → "OFF" for at least 8 seconds.

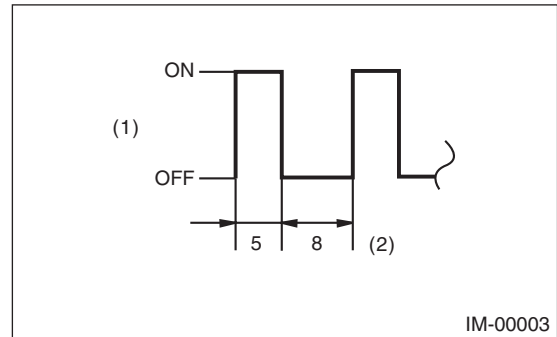

- (1) Ignition switch position
- (2) Sec.

- If the engine fails to start with a registered ignition key, detach the ignition key from ignition switch and wait for approx. 1 second until security indicator light begins to flash. And then start the engine again.
- Before performing the diagnostics, obtain all keys for the vehicle from the owner.
- Do not install or register a body integrated unit already registered to another vehicle to diagnose failures or inspect functions.

# General Description

IMMOBILIZER (DIAGNOSTICS)

## B: PREPARATION TOOL

### 1. SPECIAL TOOL

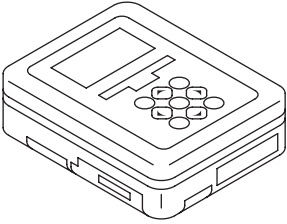
ILLUSTRATION	TOOL NUMBER	DESCRIPTION	REMARKS
 ST1B021XU0	1B021XU0	SUBARU SELECT MONITOR III KIT	Used for troubleshooting for electrical system.

### 2. GENERAL TOOL

TOOL NAME	REMARKS
Circuit tester	Used for measuring resistance, voltage and current.

## 3. Electrical Component Location

### A: LOCATION

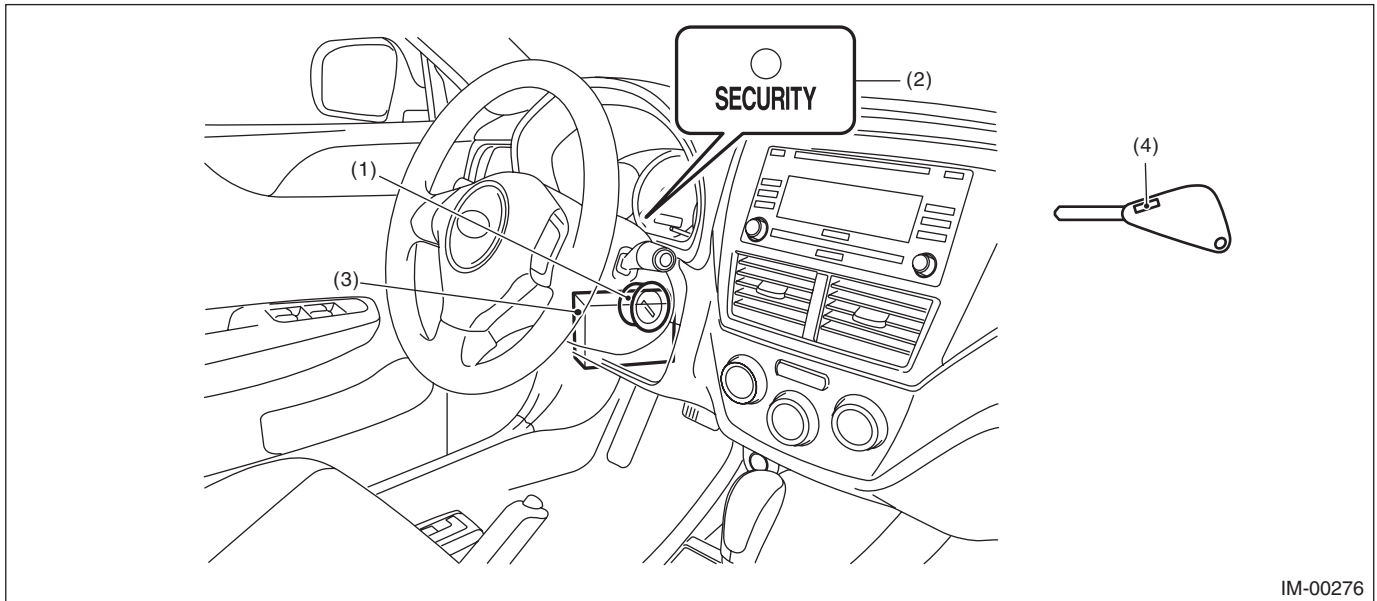

IM-00276

(1) Antenna

(3) Body integrated unit

(4) Transponder

(2) Security indicator light (LED bulb)

# Immobilizer Control Module I/O Signal

IMMOBILIZER (DIAGNOSTICS)

---

## 4. Immobilizer Control Module I/O Signal

### A: WIRING DIAGRAM

#### 1. IMMOBILIZER

<Ref. to WI-119, WIRING DIAGRAM, Immobilizer  
System.>

## 5. Subaru Select Monitor

### A: OPERATION

#### 1. HOW TO USE THE SUBARU SELECT MONITOR

- 1) Prepare the Subaru Select Monitor kit.
- 2) Connect the diagnosis cable to the Subaru Select Monitor.
- 3) Connect the Subaru Select Monitor to data link connector.
  - (1) Data link connector is located in the lower portion of the instrument panel (on the driver's side).

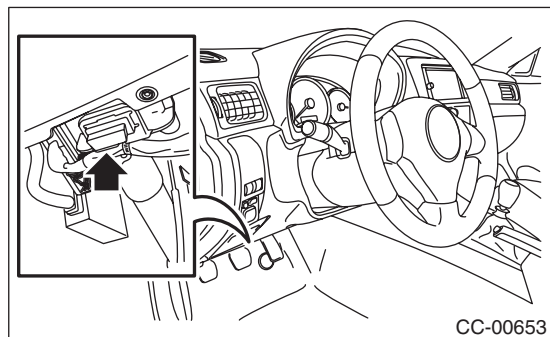

- (2) Connect the diagnosis cable to the data link connector.

#### CAUTION:

**Do not connect scan tools other than the Subaru Select Monitor.**

- 4) Turn the ignition switch to ON (engine OFF) and run the Subaru Select Monitor.
- 5) Using the Subaru Select Monitor, call up DTCs and various data, then record them.

#### 2. READ DIAGNOSTIC TROUBLE CODE (DTC) FOR ENGINE AND BODY INTEGRATED UNIT

Refer to "Read Diagnostic Trouble Code" for information about how to display a DTC. <Ref. to IM(diag)-8, Read Diagnostic Trouble Code (DTC).>

#### 3. COMMUNICATION LINE CHECK

##### NOTE:

The communication line between ECM and body integrated unit can be checked in "System Operation Check Mode". This is referred to as "Communication line check".

- 1) Connect the Subaru Select Monitor.
- 2) On the «Main Menu», select {Each System Check}.
- 3) On the «System Selection Menu» display, select {Engine Control System}.
- 4) After engine type information is displayed, select [OK].
- 5) On the «Engine Diagnosis» display, select {System Operation Check Mode}.
- 6) On the «System Operation Check Mode» display, select the {Immobilizer system}.
- 7) Start the communication line check.
- 8) Is «OK» displayed on screen?  
If displayed, go to step 9).  
If not, go to step 10).
- 9) After diagnostic results, it is determined that the circuit is not shorted. Finish the communication line check.
- 10) If a problem is detected, repair the trouble cause. <Ref. to IM(diag)-18, DTC P1572 IMM CIRCUIT FAILURE (EXCEPT ANTENNA CIRCUIT), Diagnostic Procedure with Diagnostic Trouble Code (DTC).>

# Read Diagnostic Trouble Code (DTC)

IMMOBILIZER (DIAGNOSTICS)

---

## 6. Read Diagnostic Trouble Code (DTC)

### A: OPERATION

#### 1. ECM

- 1) On the «Main Menu», select {Each System Check}.
- 2) On the «System Selection Menu» display, select {Engine Control System}.
- 3) After engine type information is displayed, select [OK].
- 4) On the «Engine Diagnosis», select {Diagnostic Code(s) Display}.
- 5) On the «Diagnostic Code(s) Display», select {Current DTC Code(s)} or {Past DTC}.

#### NOTE:

- For detailed operation procedure, refer to the «PC Application Help for Subaru Select Monitor».
- Refer to “List of Diagnostic Trouble Code (DTC)” for DTC. <Ref. to IM(diag)-13, LIST, List of Diagnostic Trouble Code (DTC).>

#### 2. BODY INTEGRATED UNIT

- 1) On the «Main Menu», select {Each System Check}.
- 2) On the «System Selection Menu», select {Integ. unit}.
- 3) After {Integ. Unit} is displayed, select [OK].
- 4) On the «Integ. unit mode failure diag», select {Diagnostic Code(s) Display}.

#### NOTE:

- For detailed operation procedure, refer to the «PC Application Help for Subaru Select Monitor».
- Refer to “List of Diagnostic Trouble Code (DTC)” for DTC. <Ref. to IM(diag)-13, LIST, List of Diagnostic Trouble Code (DTC).>



## 7. Clear Memory Mode

### A: OPERATION

#### 1. ECM

- 1) On the «Main Menu», select {Each System Check}.
- 2) On the «System Selection Menu» display, select {Engine Control System}.
- 3) After engine type information is displayed, select [OK].
- 4) On the «Engine Diagnosis», select {Clear Memory}.
- 5) When “Done” is displayed on the display screen, end the Subaru Select Monitor and turn the ignition switch to OFF.

#### NOTE:

- After the memory has been cleared, the idle air control solenoid valve must be initialized. To execute this procedure, turn the ignition switch to ON. Wait for three seconds before starting the engine.
- For detailed operation procedure, refer to the «PC Application Help for Subaru Select Monitor».

#### 2. BODY INTEGRATED UNIT

- 1) On the «Main Menu», select {Each System Check}.
- 2) On the «System Selection Menu», select {Integrated Unit}.
- 3) After {Integ. Unit} is displayed, select [OK].
- 4) On the «Integ. unit mode», select {Clear Memory}.
- 5) When “Done” is displayed on the display screen, end the Subaru Select Monitor and turn the ignition switch to OFF.

#### NOTE:

For detailed operation procedure, refer to the «PC Application Help for Subaru Select Monitor».

# Diagnostics Chart for Security Indicator Light

IMMOBILIZER (DIAGNOSTICS)

## 8. Diagnostics Chart for Security Indicator Light

### A: INSPECTION

#### 1. CHECK SECURITY INDICATOR LIGHT CIRCUIT

WIRING DIAGRAM:

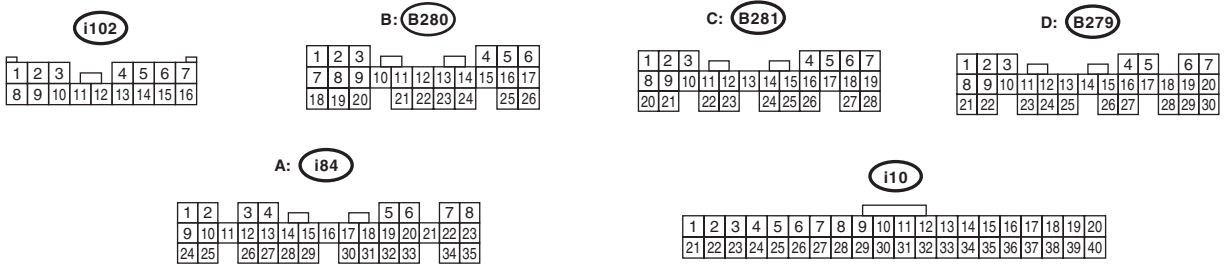
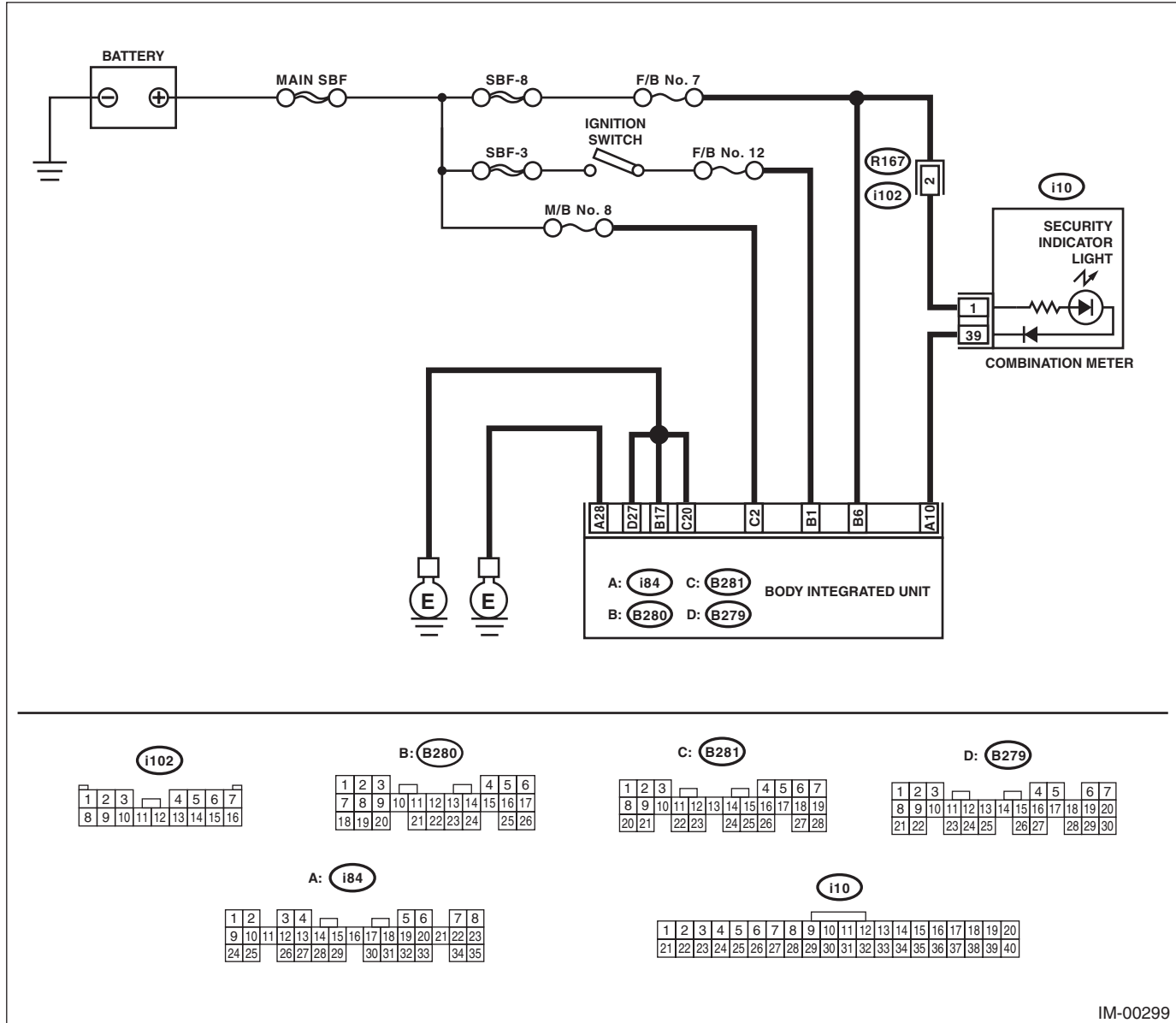

IM-00299

Step	Check	Yes	No
<b>1 CHECK SECURITY INDICATOR LIGHT.</b> 1) Turn the ignition switch to OFF. 2) Disconnect the harness connector from the body integrated unit. 3) Connect a resistor (100 Ω) between the body integrated unit harness connector terminal (i84) No. 10 and chassis ground.	Does the security indicator light illuminate?	Go to step 2.	Go to step 6.

# Diagnostics Chart for Security Indicator Light

IMMOBILIZER (DIAGNOSTICS)

Step	Check	Yes	No
<p><b>2 CHECK BODY INTEGRATED UNIT GROUND CIRCUIT.</b> Measure the resistance between the body integrated unit harness connector terminal and chassis ground. <b>Connector &amp; terminal</b> <i>(i84) No. 28 — Chassis ground:</i> <i>(B280) No. 17 — Chassis ground:</i> <i>(B281) No. 20 — Chassis ground:</i> <i>(B279) No. 27 — Chassis ground:</i></p>	Is the resistance less than 10 Ω?	Go to step 3.	Repair the open circuit of the body integrated unit ground circuit.
<p><b>3 CHECK BODY INTEGRATED UNIT IGNITION CIRCUIT.</b> 1) Turn the ignition switch to ON. 2) Measure the voltage between the body integrated unit harness connector terminal and chassis ground. <b>Connector &amp; terminal</b> <i>(B280) No. 1 (+) — Chassis ground (-):</i></p>	Is the voltage 10 V or more?	Go to step 4.	Check the harness for open or short circuit between the body integrated unit and ignition switch.
<p><b>4 CHECK BODY INTEGRATED UNIT POWER SUPPLY CIRCUIT.</b> 1) Turn the ignition switch to OFF. 2) Measure the voltage between the body integrated unit harness connector terminal and chassis ground. <b>Connector &amp; terminal</b> <i>(B280) No. 6 (+) — Chassis ground (-):</i></p>	Is the voltage 10 V or more?	Go to step 5.	Check the harness for open or short circuit between the body integrated unit and fuse.
<p><b>5 CHECK BODY INTEGRATED UNIT POWER SUPPLY CIRCUIT.</b> 1) Turn the ignition switch to OFF. 2) Disconnect the body integrated unit connector (B281). 3) Measure the voltage between connector terminals using the tester. <b>Connector &amp; terminal</b> <i>(B281) No. 2 (+) — Chassis ground (-):</i></p>	Is the voltage 10 V or more?	Replace the body integrated unit <Ref. to SL-47, Body Integrated Unit.> and replace all the ignition keys (including transponder). Execute the registration procedure next. Refer to the “PC application help for Subaru Select Monitor”.	Repair or replace the harness.
<p><b>6 CHECK COMBINATION METER CIRCUIT.</b> 1) Remove the combination meter. &lt;Ref. to IDI-13, Combination Meter.&gt; 2) Measure the voltage between combination meter harness connector terminal and chassis ground. <b>Connector &amp; terminal</b> <i>(i10) No. 1 (+) — Chassis ground (-):</i></p>	Is the voltage 10 V or more?	Go to step 7.	Check for an open or short circuit in the harness between the combination meter and fuse.
<p><b>7 CHECK COMBINATION METER CIRCUIT.</b> Measure the resistance between the body integrated unit harness connector terminal and combination meter harness connector terminals. <b>Connector &amp; terminal</b> <i>(i84) No. 10 — (i10) No. 39:</i></p>	Is the resistance less than 10 Ω?	LED bulb is defective. Replace the combination meter case assembly. <Ref. to IDI-14, DISASSEMBLY, Combination Meter.>	Repair the harness or connector.

# Diagnostics Chart for Security Indicator Light

IMMOBILIZER (DIAGNOSTICS)

## 2. CHECK KEY SWITCH CIRCUIT

WIRING DIAGRAM:

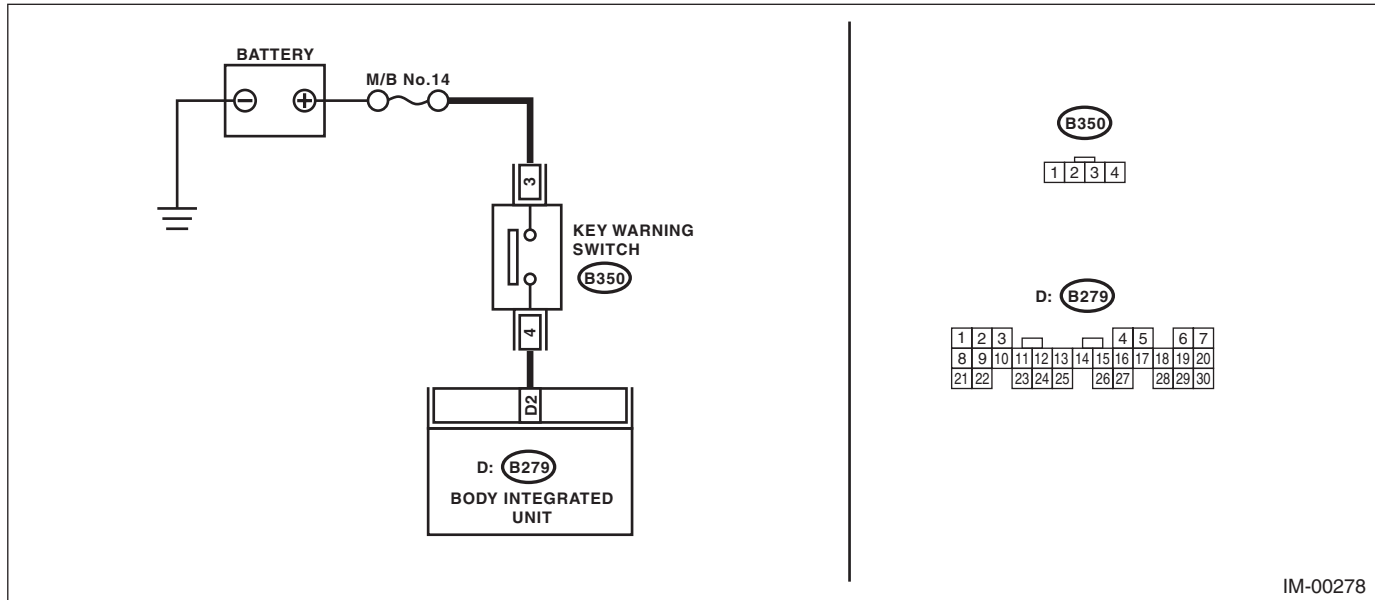

IM-00278

Step	Check	Yes	No
<b>1 CHECK POWER SUPPLY CIRCUIT.</b> 1) Disconnect the key warning switch harness connector. 2) Set the ignition switch to ACC or LOCK (with key inserted). 3) Measure the voltage between the key warning switch harness connector terminal and chassis ground. <i>Connector &amp; terminal</i> <i>(B350) No. 3 (+) — Chassis ground (-):</i>	Is the voltage 10 V or more?	Go to step 2.	Check for an open or short circuit in the harness between the key warning switch and fuse.
<b>2 CHECK KEY WARNING SWITCH.</b> 1) Insert the ignition key in the ignition switch. (OFF or ACC) 2) Measure the resistance between key warning switch connector terminals. <i>Connector &amp; terminal</i> <i>No. 3 — No. 4:</i>	Is the resistance less than 1 $\Omega$ ?	Go to step 3.	Replace the key warning switch.
<b>3 CHECK KEY WARNING SWITCH.</b> 1) Remove the ignition key from the ignition switch. 2) Measure the resistance between key warning switch connector terminals. <i>Connector &amp; terminal</i> <i>No. 3 — No. 4:</i>	Is the resistance 1 M $\Omega$ or more?	Go to step 4.	Replace the key warning switch.
<b>4 CHECK HARNESS BETWEEN KEY WARNING SWITCH AND BODY INTEGRATED UNIT.</b> 1) Disconnect the key warning switch harness connector. 2) Disconnect the harness connector from the body integrated unit. 3) Measure the resistance between the key warning switch harness connector and body integrated unit harness connector terminals. <i>Connector &amp; terminal</i> <i>(B350) No. 4 — (B279) No. 2:</i>	Is the resistance less than 10 $\Omega$ ?	Replace the body integrated unit <Ref. to SL-47, Body Integrated Unit.> and replace all the ignition keys (including transponder). Execute the registration procedure next. Refer to the "PC application help for Subaru Select Monitor".	Repair the harness between the key warning switch and body integrated unit.

# List of Diagnostic Trouble Code (DTC)

IMMOBILIZER (DIAGNOSTICS)

## 9. List of Diagnostic Trouble Code (DTC)

### A: LIST

#### 1. ECM

DTC	Item	Contents of diagnosis	Index No.
P0513	Incorrect Immobilizer Key	Incorrect immobilizer key (Use of unregistered key in body integrated unit)	<Ref. to IM(diag)-14, DTC P0513 INCORRECT IMMOBILIZER KEY, Diagnostic Procedure with Diagnostic Trouble Code (DTC).>
P1570	Antenna	Faulty antenna	<Ref. to IM(diag)-15, DTC P1570 ANTENNA, Diagnostic Procedure with Diagnostic Trouble Code (DTC).>
P1571	Reference Code Incompatibility	Reference code incompatibility between body integrated unit and ECM	<Ref. to IM(diag)-17, DTC P1571 REFERENCE CODE INCOMPATIBILITY, Diagnostic Procedure with Diagnostic Trouble Code (DTC).>
P1572	IMM Circuit Failure (Except Antenna Circuit)	<ul style="list-style-type: none"> <li>Communication failure between body integrated unit and ECM</li> <li>Failed registration between the body integrated unit and the combination meter.</li> </ul>	<Ref. to IM(diag)-18, DTC P1572 IMM CIRCUIT FAILURE (EXCEPT ANTENNA CIRCUIT), Diagnostic Procedure with Diagnostic Trouble Code (DTC).>
P1574	Key Communication Failure	Communication failure between key and the body integrated unit	<Ref. to IM(diag)-20, DTC P1574 KEY COMMUNICATION FAILURE, Diagnostic Procedure with Diagnostic Trouble Code (DTC).>
P1576	EGI Control Module EEPROM	ECM malfunctioning	<Ref. to IM(diag)-21, DTC P1576 EGI CONTROL MODULE EEPROM, Diagnostic Procedure with Diagnostic Trouble Code (DTC).>
P1577	IMM Control Module EEPROM	Body integrated unit malfunctioning	<Ref. to IM(diag)-21, DTC P1577 IMM CONTROL MODULE EEPROM, Diagnostic Procedure with Diagnostic Trouble Code (DTC).>
P1578	Meter Failure	<ul style="list-style-type: none"> <li>Reference code incompatibility between body integrated unit and combination meter</li> <li>Communication failure between body integrated unit and ECM</li> </ul>	<Ref. to IM(diag)-22, DTC P1578 METER FAILURE, Diagnostic Procedure with Diagnostic Trouble Code (DTC).>

#### NOTE:

Perform diagnosis of engine DTC when a DTC other than an immobilizer DTC is detected. <Ref. to EN(STI)(diag)-80, List of Diagnostic Trouble Code (DTC).>

#### 2. BODY INTEGRATED UNIT

DTC	Item	Contents of diagnosis	Index No.	Relation between ECM and DTC
B1401	M Collation NG	Reference code incompatibility between body integrated unit and combination meter	<Ref. to IM(diag)-22, DTC B1401 M COLLATION NG, Diagnostic Procedure with Diagnostic Trouble Code (DTC).>	P1578
B1402	Immobilizer Key Collation NG	<ul style="list-style-type: none"> <li>Incorrect immobilizer key (Use of unregistered key in body integrated unit)</li> <li>Faulty antenna</li> </ul>	<Ref. to IM(diag)-22, DTC B1402 IMMOBILIZER KEY COLLATION NG, Diagnostic Procedure with Diagnostic Trouble Code (DTC).>	<ul style="list-style-type: none"> <li>P0513</li> <li>P1570</li> <li>P1574</li> </ul>
B1403	E/G Request NG	Communication failure between body integrated unit and ECM	<Ref. to IM(diag)-22, DTC B1403 E/G REQUEST NG, Diagnostic Procedure with Diagnostic Trouble Code (DTC).>	P1572

#### NOTE:

In immobilizer system, performing the starter relay control. When the body integrated unit detect the inconformity of reference code, immediately out put the starter relay cut signal to ECM, and then ECM stop the starter relay operation. In this case, engine does not start, and DTC is not recorded in ECM. Check that the engine does not start on the DTC of body integrated unit.

# Diagnostic Procedure with Diagnostic Trouble Code (DTC)

IMMOBILIZER (DIAGNOSTICS)

## 10. Diagnostic Procedure with Diagnostic Trouble Code (DTC)

### A: DTC P0513 INCORRECT IMMOBILIZER KEY

#### DTC DETECTING CONDITION:

Incorrect immobilizer key (Use of unregistered key in body integrated unit)

	Step	Check	Yes	No
1	<b>PERFORM REGISTRATION ON IGNITION KEY.</b> Perform registration on all keys of the vehicle. Refer to the "PC application help for Subaru Select Monitor".	Is registration for all keys complete?	END	Replace ignition keys (including transponder) which cannot be registered. Go to step 2.
2	<b>PERFORM REGISTRATION ON IGNITION KEY.</b> Perform registration on all keys of the vehicle. Refer to the "PC application help for Subaru Select Monitor".	Is registration for all keys complete?	END	Replace the body integrated unit. <Ref. to SL-47, Body Integrated Unit.> Replace all ignition keys (including the transponder). Execute the registration procedure next. Refer to the "PC application help for Subaru Select Monitor".

# Diagnostic Procedure with Diagnostic Trouble Code (DTC)

IMMOBILIZER (DIAGNOSTICS)

## B: DTC P1570 ANTENNA

### DTC DETECTING CONDITION:

Faulty antenna

### WIRING DIAGRAM:

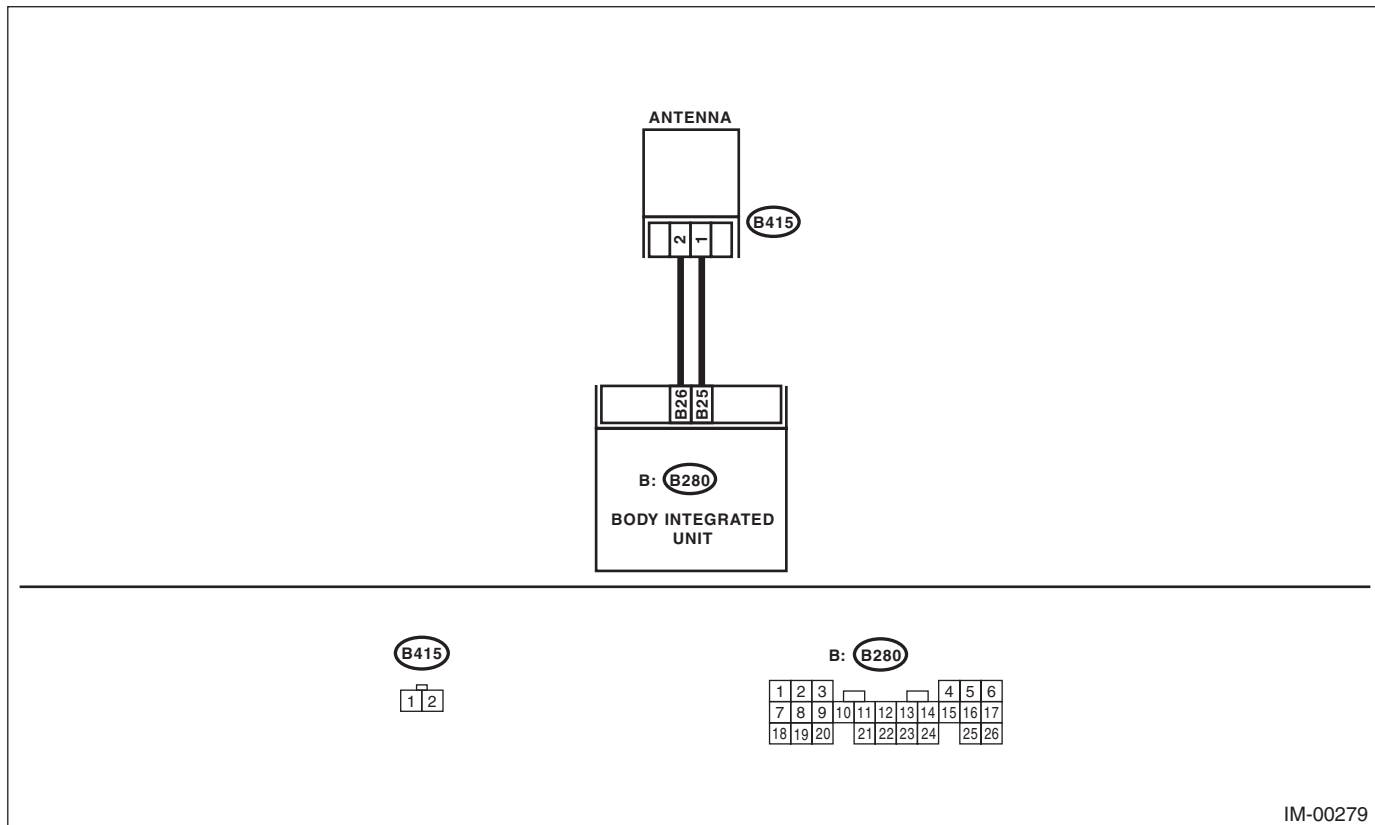

IM-00279

Step	Check	Yes	No
<b>1 CHECK THE ANTENNA CIRCUIT.</b> 1) Turn the ignition switch to OFF. 2) Disconnect the harness connector from the antenna. <Ref. to SL-50, Immobilizer Antenna.> 3) Measure the resistance of the antenna circuit. <i>Connector &amp; terminal</i> <i>(B415) No. 1 — No. 2:</i>	Is the resistance less than 10 Ω?	Go to step 2.	Replace the antenna. <Ref. to SL-50, Immobilizer Antenna.>
<b>2 CHECK THE ANTENNA CIRCUIT.</b> 1) Disconnect the harness connector from the body integrated unit. 2) Measure the resistance between harness connector and chassis ground. <i>Connector &amp; terminal</i> <i>(B280) No. 26 — Chassis ground:</i>	Is the resistance less than 10 Ω?	Repair the harness.	Go to step 3.
<b>3 CHECK THE ANTENNA CIRCUIT.</b> Measure the resistance between harness connector and chassis ground. <i>Connector &amp; terminal</i> <i>(B280) No. 25 — Chassis ground:</i>	Is the resistance less than 10 Ω?	Repair the harness.	Go to step 4.

# Diagnostic Procedure with Diagnostic Trouble Code (DTC)

## IMMOBILIZER (DIAGNOSTICS)

Step	Check	Yes	No
<b>4 CHECK THE ANTENNA CIRCUIT.</b> 1) Turn the ignition switch to ON. 2) Measure the voltage between harness connector and chassis ground. <b>Connector &amp; terminal</b> <b>(B280) No. 26 (+) — Chassis ground (-):</b>	Is the voltage 0 V?	Go to step 5.	Repair the harness.
<b>5 CHECK THE ANTENNA CIRCUIT.</b> Measure the voltage between harness connector and chassis ground. <b>Connector &amp; terminal</b> <b>(B280) No. 25 (+) — Chassis ground (-):</b>	Is the voltage 0 V?	Go to step 6.	Because the battery voltage or ignition switch "ON" circuit is shorted, repair the harness between the body integrated unit and antenna.
<b>6 CHECK BODY INTEGRATED UNIT FUNCTION.</b> 1) Turn the ignition switch to OFF. 2) Connect the harness connector to the body integrated unit. 3) Insert the key into the ignition switch, then measure changes in voltage between the antenna harness connectors. <b>Connector &amp; terminal</b> <b>(B280) No. 25 (+) — No. 26 (-):</b>	Is the voltage -30 — 30 V? (Approx. 0.1 second after inserting the key) Is the voltage 0 V? (Approx. 1 second after inserting the key)	Go to step 7.	Replace the body integrated unit. <Ref. to SL-47, Body Integrated Unit.> Replace all ignition keys (including the transponder). Execute the registration procedure next. Refer to the "PC application help for Subaru Select Monitor".
<b>7 CHECK IGNITION KEY (TRANSPONDER).</b> 1) Remove the key from ignition switch. 2) Start the engine using other key which is already registered.	Does the engine start?	Replace the ignition key (including the transponder). Execute the registration procedure next. Refer to the "PC application help for Subaru Select Monitor".	Replace the body integrated unit. <Ref. to SL-47, Body Integrated Unit.> Replace all ignition keys (including the transponder). Execute the registration procedure next. Refer to the "PC application help for Subaru Select Monitor".



# Diagnostic Procedure with Diagnostic Trouble Code (DTC)

IMMOBILIZER (DIAGNOSTICS)

## C: DTC P1571 REFERENCE CODE INCOMPATIBILITY

### DTC DETECTING CONDITION:

Reference code incompatibility between body integrated unit and ECM

	Step	Check	Yes	No
1	<b>PERFORM REGISTRATION ON IGNITION KEY.</b> Perform registration on all keys of the vehicle. Refer to the "PC application help for Subaru Select Monitor".	Is registration for all keys complete?	END	Go to step 2.
2	<b>CHECK FOR ANY OTHER DTC ON DISPLAY.</b>	Is any other immobilizer DTC displayed?	Check the appropriate DTC using the List of Diagnostic Trouble Code (DTC). <Ref. to IM(diag)-13, List of Diagnostic Trouble Code (DTC).>Execute the registration procedure next. Refer to the "PC application help for Subaru Select Monitor".	Replace the ECM. <Ref. to FU(STI)-49, Engine Control Module (ECM).> Replace the body integrated unit <Ref. to SL-47, Body Integrated Unit.>and replace all the ignition keys (including transponder). Execute the registration procedure next. Refer to the "PC application help for Subaru Select Monitor".

# Diagnostic Procedure with Diagnostic Trouble Code (DTC)

IMMOBILIZER (DIAGNOSTICS)

## D: DTC P1572 IMM CIRCUIT FAILURE (EXCEPT ANTENNA CIRCUIT)

### DTC DETECTING CONDITION:

Communication failure between body integrated unit and ECM

### WIRING DIAGRAM:

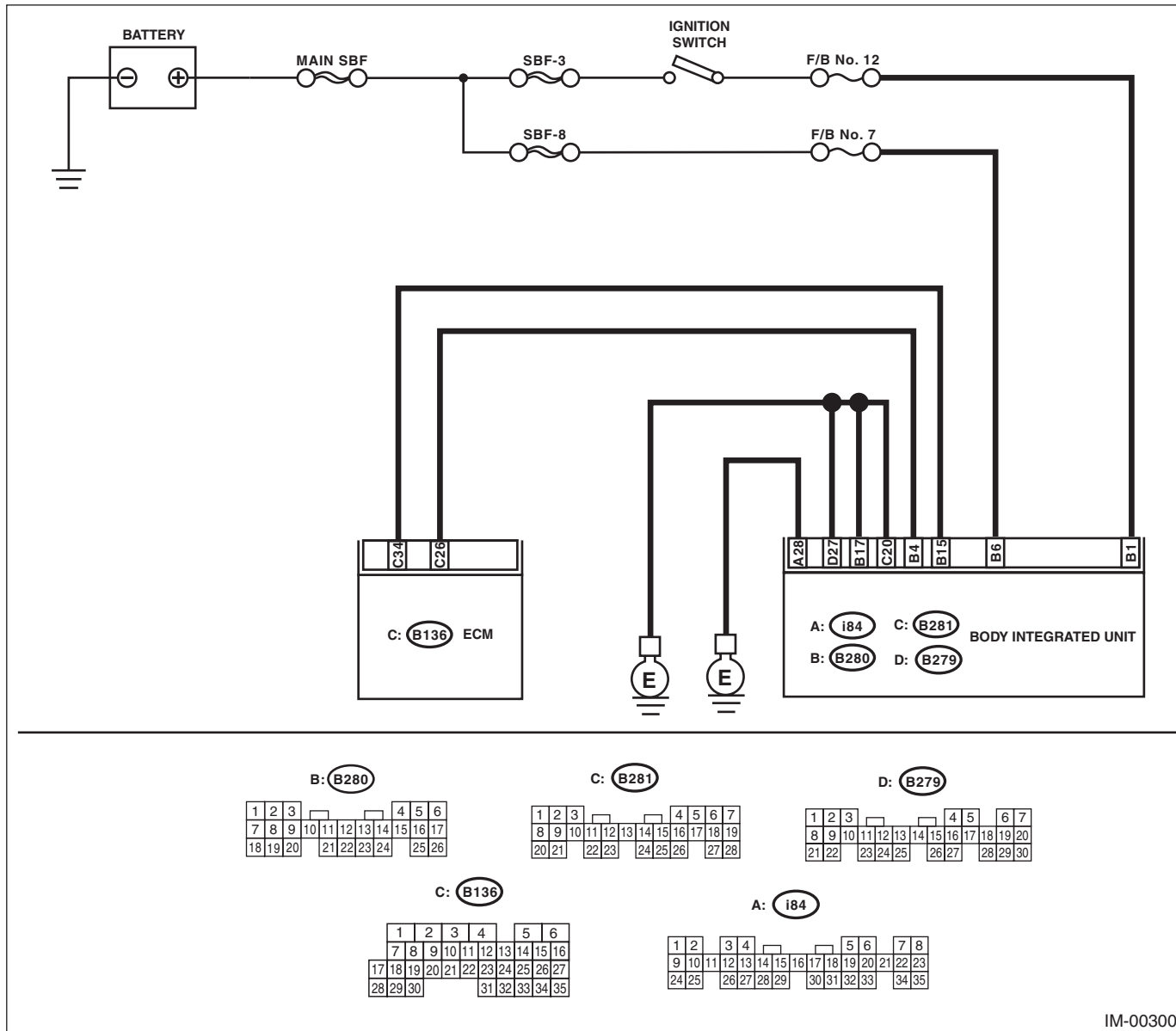

IM-00300

# Diagnostic Procedure with Diagnostic Trouble Code (DTC)

IMMOBILIZER (DIAGNOSTICS)

Step	Check	Yes	No
<p><b>1</b></p> <p><b>CHECK BODY INTEGRATED UNIT POWER SUPPLY CIRCUIT.</b></p> <p>1) Turn the ignition switch to OFF.</p> <p>2) Disconnect the harness connector from the body integrated unit.</p> <p>3) Measure the voltage between the body integrated unit harness connector terminal and chassis ground.</p> <p><b>Connector &amp; terminal</b> <b>(B280) No. 6 (+) — Chassis ground (-):</b></p>	Is the voltage 10 V or more?	Go to step 2.	Check the harness for open or short circuit between the body integrated unit and fuse.
<p><b>2</b></p> <p><b>CHECK BODY INTEGRATED UNIT POWER SUPPLY CIRCUIT.</b></p> <p>1) Turn the ignition switch to ON.</p> <p>2) Measure the voltage between the body integrated unit harness connector terminal and chassis ground.</p> <p><b>Connector &amp; terminal</b> <b>(B280) No. 1 (+) — Chassis ground (-):</b></p>	Is the voltage 10 V or more?	Go to step 3.	Check the harness for open or short circuit between the body integrated unit and ignition switch.
<p><b>3</b></p> <p><b>CHECK BODY INTEGRATED UNIT GROUND CIRCUIT.</b></p> <p>1) Turn the ignition switch to OFF.</p> <p>2) Measure the resistance between the body integrated unit harness connector terminal and chassis ground.</p> <p><b>Connector &amp; terminal</b> <b>(i84) No. 28 — Chassis ground:</b> <b>(B280) No. 17 — Chassis ground:</b> <b>(B281) No. 20 — Chassis ground:</b> <b>(B279) No. 27 — Chassis ground:</b></p>	Is the resistance less than 10 Ω?	Go to step 4.	Repair the open circuit of the body integrated unit ground circuit.
<p><b>4</b></p> <p><b>CHECK HARNESS BETWEEN BODY INTEGRATED UNIT AND ECM.</b></p> <p>1) Disconnect the harness connector from the ECM and body integrated unit.</p> <p>2) Measure the resistance between the body integrated unit harness connector and ECM harness connector terminals.</p> <p><b>Connector &amp; terminal</b> <b>(B280) No. 4 — (B136) No. 26:</b></p>	Is the resistance less than 10 Ω?	Go to step 5.	Repair the open circuit of the harness between the body integrated unit and ECM.
<p><b>5</b></p> <p><b>CHECK HARNESS BETWEEN BODY INTEGRATED UNIT AND ECM.</b></p> <p>Measure the resistance between the body integrated unit harness connector and ECM harness connector terminals.</p> <p><b>Connector &amp; terminal</b> <b>(B280) No. 15 — (B136) No. 34:</b></p>	Is the resistance less than 10 Ω?	Go to step 6.	Repair the open circuit of the harness between the body integrated unit and ECM.
<p><b>6</b></p> <p><b>CHECK COMMUNICATION CIRCUIT HARNESS.</b></p> <p>1) Turn the ignition switch to ON. (engine OFF)</p> <p>2) Measure the voltage between the body integrated unit harness connector terminal and chassis ground.</p> <p><b>Connector &amp; terminal</b> <b>(B280) No. 4 (+) — Chassis ground (-):</b> <b>(B280) No. 15 (+) — Chassis ground (-):</b></p>	Is the voltage 0 V?	Go to step 7.	Because the battery voltage or ignition switch "ON" circuit is shorted, repair the harness between the body integrated unit and ECM.

# Diagnostic Procedure with Diagnostic Trouble Code (DTC)

## IMMOBILIZER (DIAGNOSTICS)

Step	Check	Yes	No
<b>7 CHECK COMMUNICATION CIRCUIT HARNESS.</b> Measure the voltage between the ECM harness connector terminal and engine ground. <b>Connector &amp; terminal</b> <b>(B136) No. 26 (+) — Engine ground (-):</b> <b>(B136) No. 34 (+) — Engine ground (-):</b>	Is the voltage 0 V?	Go to step 8.	Because the battery voltage or ignition switch "ON" circuit is shorted, repair the harness between the body integrated unit and ECM.
<b>8 CHECK ECM BY COMMUNICATION LINE CHECK.</b> 1) Connect the harness connector to the ECM. 2) Disconnect the harness connector from the body integrated unit. 3) Start the communication line short check. <Ref. to IM(diag)-7, COMMUNICATION LINE CHECK, OPERATION, Subaru Select Monitor.>	Is the communication line check OK?	Replace the body integrated unit. <Ref. to SL-47, Body Integrated Unit.> Replace all ignition keys (including the transponder). Execute the registration procedure next. Refer to the "PC application help for Subaru Select Monitor".	Replace the ECM. <Ref. to FU(STI)-49, Engine Control Module (ECM).> Next, execute the registration procedure. Refer to the "PC application help for Subaru Select Monitor".

### NOTE:

After inspection, input the DTC code refer to <Ref. to IM(diag)-22, DTC P1578 METER FAILURE, Diagnostic Procedure with Diagnostic Trouble Code (DTC).>.

## E: DTC P1574 KEY COMMUNICATION FAILURE

### DTC DETECTING CONDITION:

Communication failure between key and the body integrated unit

Step	Check	Yes	No
<b>1 CHECK BODY INTEGRATED UNIT FUNCTION.</b> Insert the key into the ignition switch (LOCK position), then measure changes in voltage between the antenna connectors. <b>Connector &amp; terminal</b> <b>(B351) No. 1 (+) — No. 2 (-):</b>	Is the voltage -30 — 30 V? (Approx. 0.1 second after inserting the key) Is the voltage 0 V? (Approx. 1 second after inserting the key)	Go to step 2.	Replace the body integrated unit. <Ref. to SL-47, Body Integrated Unit.> Replace all ignition keys (including the transponder). Execute the registration procedure next. Refer to the "PC application help for Subaru Select Monitor".
<b>2 CHECK IGNITION KEY (TRANSPONDER).</b> 1) Remove the key from ignition switch. 2) Start the engine using other key which is already registered.	Does the engine start?	Replace the ignition key (including the transponder). Execute the registration procedure next. Refer to the "PC application help for Subaru Select Monitor".	Replace the body integrated unit. <Ref. to SL-47, Body Integrated Unit.> Replace all ignition keys (including the transponder). Execute the registration procedure next. Refer to the "PC application help for Subaru Select Monitor".

# Diagnostic Procedure with Diagnostic Trouble Code (DTC)

IMMOBILIZER (DIAGNOSTICS)

## F: DTC P1576 EGI CONTROL MODULE EEPROM

### DTC DETECTING CONDITION:

- ECM malfunctioning
- Inaccessible ROM in ECM during key registration.

	Step	Check	Yes	No
1	<b>PERFORM REGISTRATION ON IGNITION KEY.</b> Perform registration on all keys of the vehicle. Refer to the "PC application help for Subaru Select Monitor".	Is registration for all keys complete?	Make sure it is possible to start the engine with all keys that have been taught. This completes the work.	Go to step 2.
2	<b>PERFORM REGISTRATION ON IGNITION KEY.</b> Perform registration on all keys of the vehicle. Refer to the "PC application help for Subaru Select Monitor".	Is registration for all keys complete?	Make sure it is possible to start the engine with all keys that have been taught. This completes the work.	Go to step 3.
3	<b>PERFORM REGISTRATION ON IGNITION KEY.</b> Perform registration on all keys of the vehicle. Refer to the "PC application help for Subaru Select Monitor".	Is registration for all keys complete?	Make sure it is possible to start the engine with all keys that have been taught. This completes the work.	Replace the ECM. <Ref. to FU(STI)-49, Engine Control Module (ECM).>

## G: DTC P1577 IMM CONTROL MODULE EEPROM

### DTC DETECTING CONDITION:

- Body integrated unit malfunctioning
- Failed to access the ROM inside the body integrated unit.

	Step	Check	Yes	No
1	<b>PERFORM REGISTRATION ON IGNITION KEY.</b> Perform registration on all keys of the vehicle. Refer to the "PC application help for Subaru Select Monitor".	Is registration for all keys complete?	Make sure it is possible to start the engine with all keys that have been taught. This completes the work.	Go to step 2.
2	<b>PERFORM REGISTRATION ON IGNITION KEY.</b> Perform registration on all keys of the vehicle. Refer to the "PC application help for Subaru Select Monitor".	Is registration for all keys complete?	Make sure it is possible to start the engine with all keys that have been taught. This completes the work.	Go to step 3.
3	<b>PERFORM REGISTRATION ON IGNITION KEY.</b> Perform registration on all keys of the vehicle. Refer to the "PC application help for Subaru Select Monitor".	Is registration for all keys complete?	Make sure it is possible to start the engine with all keys that have been taught. This completes the work.	Replace the body integrated unit. <Ref. to SL-47, Body Integrated Unit.>

# Diagnostic Procedure with Diagnostic Trouble Code (DTC)

## IMMOBILIZER (DIAGNOSTICS)

### H: DTC P1578 METER FAILURE

#### DTC DETECTING CONDITION:

Reference code incompatibility between combination meter and body integrated unit

Step	Check	Yes	No
<b>1</b> <b>CHECK DIAGNOSTIC TROUBLE CODE (DTC).</b> Read the DTC of body integrated unit using Subaru Select Monitor.	Is DTC B1401 detected?	Go to step 2.	<Ref. to IM(diag)-18, DTC P1572 IMM CIRCUIT FAILURE (EXCEPT ANTENNA CIRCUIT), Diagnostic Procedure with Diagnostic Trouble Code (DTC).>
<b>2</b> <b>CHECK LAN COMMUNICATION SYSTEM.</b> Inspect LAN system. <Ref. to LAN(diag)-2, Basic Diagnostic Procedure.>	DTC U1300, U1301, U1302, B1100 B1101 of the body integrated unit is displayed.	Perform the diagnosis according to DTC. <Ref. to LAN(diag)-31, List of Diagnostic Trouble Code (DTC).>	Go to step 3.
<b>3</b> <b>CHECK COMBINATION METER.</b> 1) Make a registration of immobilizer. Refer to the "PC application help for Subaru Select Monitor". 2) Start the engine.	Does the engine start?	System is normal.	Replace the combination meter. <Ref. to IDI-13, REMOVAL, Combination Meter.>

### I: DTC B1401 M COLLATION NG

#### NOTE:

Refer to DTC P1578 "METER FAILURE" for diagnostic procedure. <Ref. to IM(diag)-22, DTC P1578 METER FAILURE, Diagnostic Procedure with Diagnostic Trouble Code (DTC).>

### J: DTC B1402 IMMOBILIZER KEY COLLATION NG

#### NOTE:

Refer to DTC P1570 "ANTENNA" <Ref. to IM(diag)-15, DTC P1570 ANTENNA, Diagnostic Procedure with Diagnostic Trouble Code (DTC).>, DTC P1574 "KEY COMMUNICATION FAILURE" <Ref. to IM(diag)-20, DTC P1574 KEY COMMUNICATION FAILURE, Diagnostic Procedure with Diagnostic Trouble Code (DTC).> DTC P0513 "INCORRECT IMMOBILIZER KEY" <Ref. to IM(diag)-14, DTC P0513 INCORRECT IMMOBILIZER KEY, Diagnostic Procedure with Diagnostic Trouble Code (DTC).>.

### K: DTC B1403 E/G REQUEST NG

#### NOTE:

For the diagnostic procedure, refer to DTC P1572 "IMM CIRCUIT FAILURE (EXCEPT ANTENNA CIRCUIT)" <Ref. to IM(diag)-18, DTC P1572 IMM CIRCUIT FAILURE (EXCEPT ANTENNA CIRCUIT), Diagnostic Procedure with Diagnostic Trouble Code (DTC).>.