

# **LAN SYSTEM (DIAGNOSTICS)**

### 1. General

#### A: LAN

- The LAN system\*<sup>1</sup> enables data sharing among computers, that otherwise are left to function as independent systems, by connecting them via communications lines.
- Introduction of the LAN\*<sup>1</sup> system has improved equipment and functions while reducing the weight of the vehicle by eliminating a considerable amount of harnesses.
- Data transmission/reception is via CAN \*<sup>2</sup>, which offers high-speed communication and also ensures a high level of reliability.
- Depending on control requirements, two transmission rates are used: high-speed CAN running at 500 Kbps, which is an ISO 11898 and manages power-related units; and low-speed CAN running at 125 Kbps, which is an ISO 11519-2 and manages body-related functions.
- Networks running at different transmission rates usually cannot share data between them, however, the body integrated unit with a gateway (hookup) function enables data sharing between different-rate networks.

#### NOTE:

\*<sup>1</sup>: LAN (Local Area Network). A system where multiple computers (units) are linked via serial communication for data sharing.

\*<sup>2</sup>: CAN (Controller Area Network). A serial communications protocol in compliance with ISO 11898 and ISO 11519-2.

#### B: CAN

- CAN is a serial communications protocol in compliance with relevant ISO standards.
- With its high bit rates, CAN enables quick, large-volume data transmission/reception.
- Based on continuous change in bus level (logical signals: low “0” and high “1”) stemming from voltage difference between CAN\_High and CAN\_Low, data and other frames are configured for message identification.
- If an error is detected, CAN’s fault confinement feature prevents the error from impacting units.
- If an error is detected, an error frame (notification that an error has been detected) is sent to units, telling them not to perform control based on data including errors.
- Depending on the status of the error detected, transmission/reception of the relevant data will be aborted.

**C: COMPARISON BETWEEN CAN AND CONVENTIONAL DATA COMMUNICATION**

- With conventional data communication, each sensor relies on its dedicated wiring for message to be sent between units. As data volume grows, so does the volume of wiring.
- CAN uses only one twisted-pair cable to connect between units for shared communication.

**1. CONVENTIONAL COMMUNICATION**

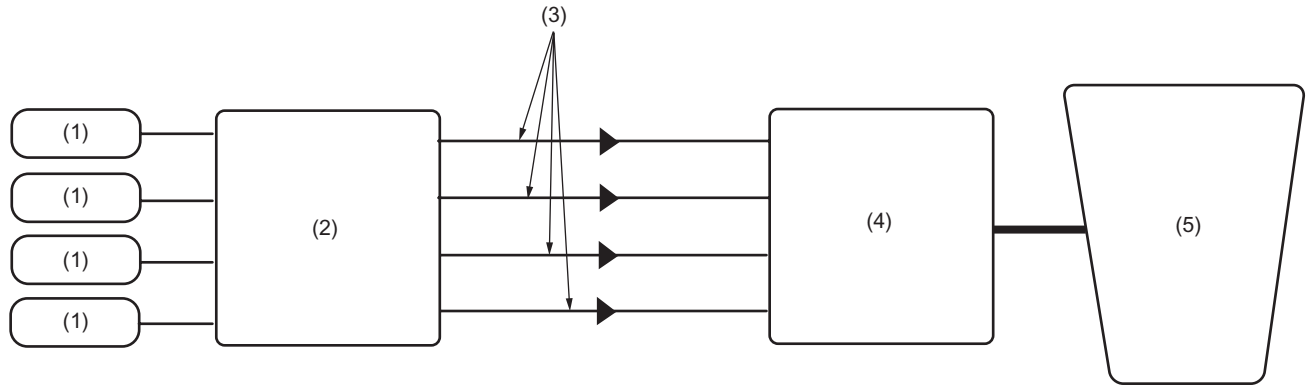

LAN00045

- |                          |                  |
|--------------------------|------------------|
| (1) Sensor               | (4) TCM          |
| (2) ECM                  | (5) Transmission |
| (3) Communication wiring |                  |

**NOTE:**

Conventional data communication needs as many data transmission lines as sensors used. (parallel signals)

# GENERAL

## LAN SYSTEM

---

### 2. CAN COMMUNICATION

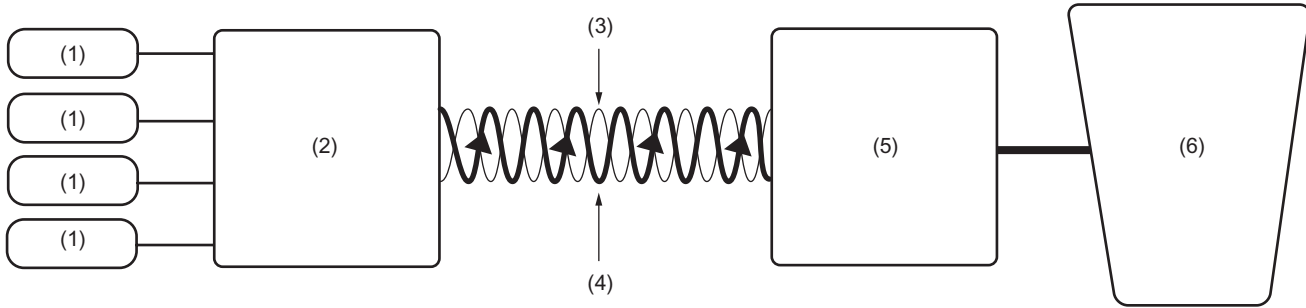

LAN00046

- |                   |                   |
|-------------------|-------------------|
| (1) Sensor        | (4) CAN line (HI) |
| (2) ECM           | (5) TCM           |
| (3) CAN line (LO) | (6) Transmission  |

#### NOTE:

- With CAN, one twisted-pair cable (2 wires) manages transmission of all data. (serial communication)
- The main wire runs between the terminal resistor on the ECM and that on the ABSCM or vehicle dynamics control (VDC) CM & H/U. Other units are connected, in parallel, to the main wire via branch wires.

## 2. LAN Configuration

### A: NETWORK ARCHITECTURE

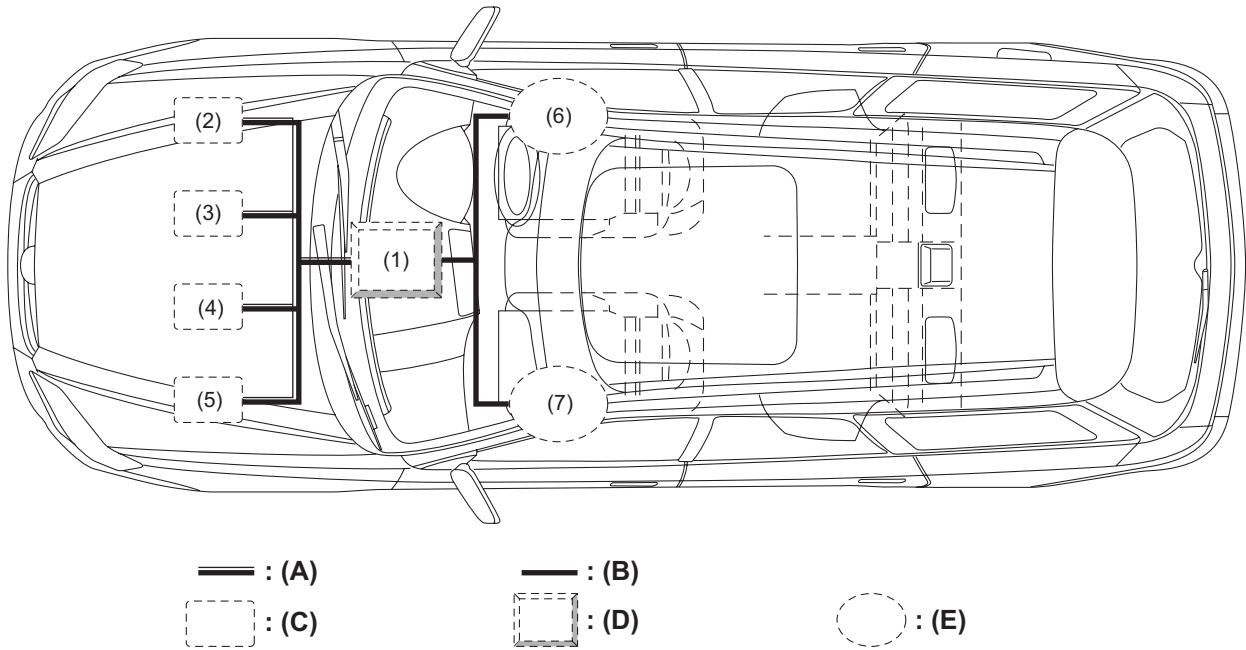

LAN00131

- |  |  |                                      |
|--|--|--------------------------------------|
| (1) Body integrated unit                         | (6) Combination meter                        | <b>(A)</b> High-speed bus (500 Kbps) |
| (2) ECM  | (7) A/C ECM<br>(vehicles with automatic A/C) | <b>(B)</b> Low-speed bus (125 Kbps)  |
| (3) TCM  |  | <b>(C)</b> High-speed system units   |
| (4) ABSCM or VDCCM & H/U                         |  | <b>(D)</b> Body integrated unit      |
| (5) Steering angle sensor<br>(vehicles with VDC) |  | <b>(E)</b> Low-speed system units    |

**NOTE:**

- Bit rate 500 Kbps: The bit rate of 500 Kbps means that 500,000 bits of data are transmitted per second.
- Bit rate 125 Kbps: The bit rate of 125 Kbps means that 125,000 bits of data are transmitted per second.

# LAN CONFIGURATION

## LAN SYSTEM

### B: LAN CONNECTED UNITS

#### 1. UNITS CONNECTED VIA HIGH-SPEED LAN

Vehicle type	Sedan				Wagon			
Transmission	MT		AT		MT		AT	
Vehicles with ABS/VDC	ABS	Vehicles with VDC	ABS	Vehicles with VDC	ABS	Vehicles with VDC	ABS	Vehicles with VDC
ECM	○	○	○	○	○	○	○	○
TCM			○	○			○	○
ABSCM & H/U	○		○		○		○	
VDCCM & H/U		○		○		○		○
Steering angle sensor unit		○		○		○		○
Body integrated unit	○	○	○	○	○	○	○	○

○: Installed units

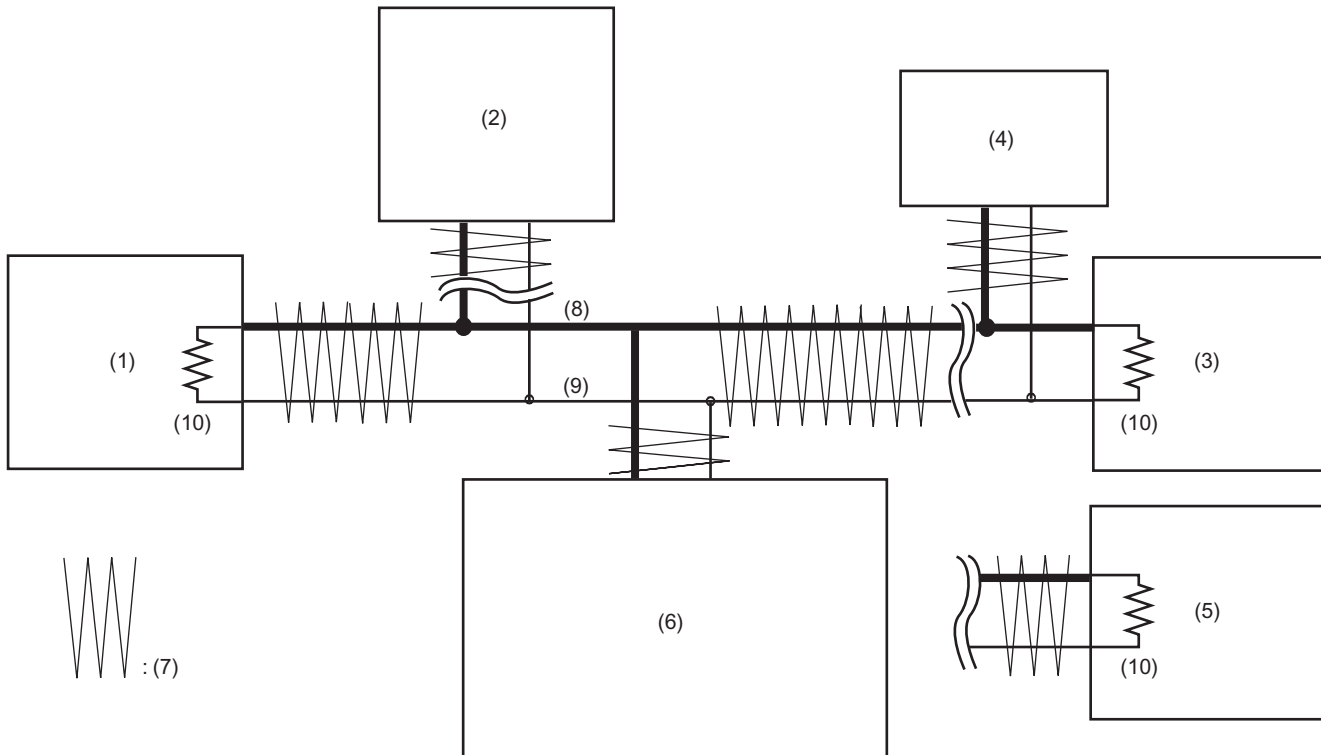

LAN00048

- |   |                          |
|---|--------------------------|
| (1) ECM                                       | (6) Body integrated unit |
| (2) TCM (AT models)                           | (7) Twisted-pair cable   |
| (3) VDCCM & H/U (vehicles with VDC)           | (8) CAN_HI               |
| (4) Steering angle sensor (vehicles with VDC) | (9) CAN_LO               |
| (5) ABSCM & H/U (vehicles without VDC)        | (10) Terminal resistor   |

**NOTE:**

- Terminal resistors built into the ECM and VDCCM & H/U stabilize traffic on the bus, and enables signals distinction from the voltage difference between the two bus lines (CAN\_High and CAN\_Low). These bus lines are called the main lines. Other units are connected in parallel to the main lines. These wires are called branch lines.
- If one bus line of the main lines becomes open, this is detected as an error and communication becomes no longer possible.
- If one bus line of a pair of branch lines becomes open, communication with the unit connected to the branch line becomes no longer possible, however, communication with other units remain intact. (The error will be displayed.)

# LAN CONFIGURATION

## LAN SYSTEM

### 2. UNITS CONNECTED VIA LOW-SPEED LAN

Vehicle type	Sedan								Wagon							
	Yes		No		Yes		No		Yes		No		Yes		No	
Navigation system	<input type="checkbox"/>	<input type="checkbox"/>	<input type="checkbox"/>	<input type="checkbox"/>	<input type="checkbox"/>	<input type="checkbox"/>	<input type="checkbox"/>	<input type="checkbox"/>	<input type="checkbox"/>	<input type="checkbox"/>	<input type="checkbox"/>	<input type="checkbox"/>	<input type="checkbox"/>	<input type="checkbox"/>	<input type="checkbox"/>	<input type="checkbox"/>
A/C unit (vehicles with auto A/C)	<input type="checkbox"/>	<input type="checkbox"/>	<input type="checkbox"/>	<input type="checkbox"/>	<input type="checkbox"/>	<input type="checkbox"/>	<input type="checkbox"/>	<input type="checkbox"/>	<input type="checkbox"/>	<input type="checkbox"/>	<input type="checkbox"/>	<input type="checkbox"/>	<input type="checkbox"/>	<input type="checkbox"/>	<input type="checkbox"/>	<input type="checkbox"/>
Combination meter	<input type="checkbox"/>	<input type="checkbox"/>	<input type="checkbox"/>	<input type="checkbox"/>	<input type="checkbox"/>	<input type="checkbox"/>	<input type="checkbox"/>	<input type="checkbox"/>	<input type="checkbox"/>	<input type="checkbox"/>	<input type="checkbox"/>	<input type="checkbox"/>	<input type="checkbox"/>	<input type="checkbox"/>	<input type="checkbox"/>	<input type="checkbox"/>
Body integrated unit	<input type="checkbox"/>	<input type="checkbox"/>	<input type="checkbox"/>	<input type="checkbox"/>	<input type="checkbox"/>	<input type="checkbox"/>	<input type="checkbox"/>	<input type="checkbox"/>	<input type="checkbox"/>	<input type="checkbox"/>	<input type="checkbox"/>	<input type="checkbox"/>	<input type="checkbox"/>	<input type="checkbox"/>	<input type="checkbox"/>	<input type="checkbox"/>

○: Installed units

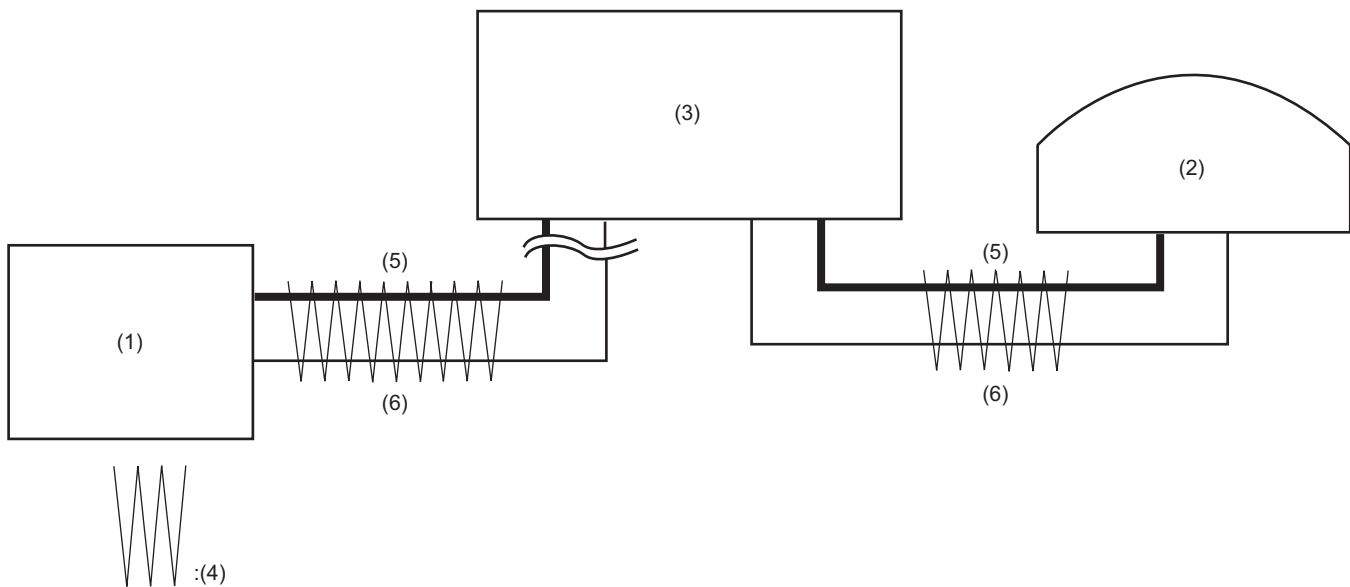

LAN00132

- |   |                        |
|---|------------------------|
| (1) Auto A/C ECM (vehicles with auto A/C) | (4) Twisted-pair cable |
| (2) Combination meter                     | (5) CAN_HI             |
| (3) Body integrated unit                  | (6) CAN_LO             |

**NOTE:**

In low-speed CAN, the system still allows communication even if one of the twisted-pair cable wires becomes open. (Errors will be detected.)

The high- and low-speed LANs described above, and the IE\_Bus, dedicated communication lines, and select monitor communication, etc. comprise the vehicle's data communication system.



# LAN CONFIGURATION

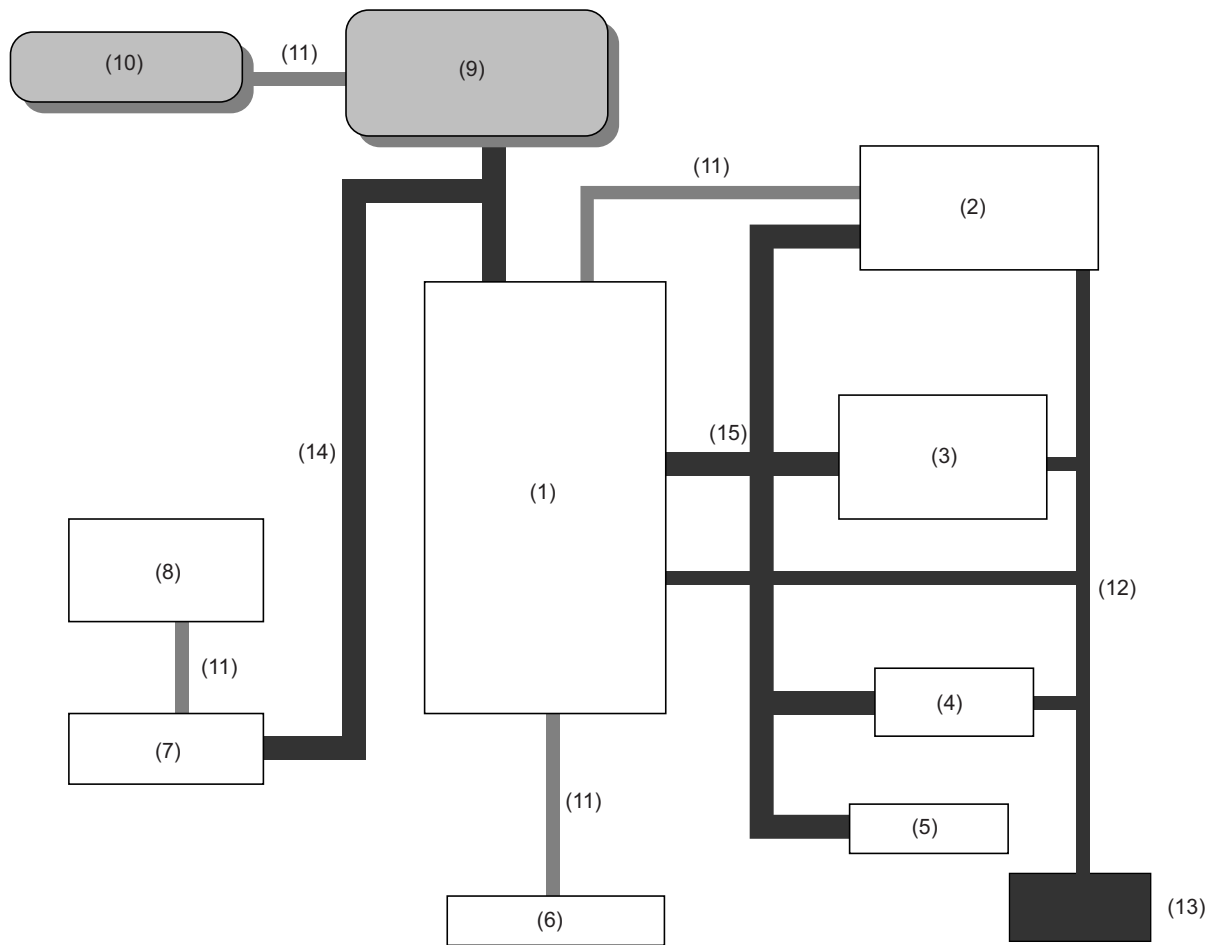

LAN00133

- |                           |  |  |
|---------------------------|--|--|
| (1) Body integrated unit  | (6) Keyless entry receiver                   | (11) Dedicated communication line            |
| (2) ECM                   | (7) A/C ECM (vehicles with auto A/C)         | (12) Select monitor communication wiring     |
| (3) TCM                   | (8) Audio and A/C control panel              | (13) Select monitor                          |
| (4) ABSCM or VDCCM        | (9) Combination meter                        | (14) Low-speed CAN (body control system)     |
| (5) Steering angle sensor | (10) Clock (vehicles without monitor screen) | (15) High-speed CAN (driving control system) |

## 3. What is CAN?

### A: FEATURES

- Some of the basic specifications of CAN, intended to ensure smooth multiplex data communication, are described below.

#### 1. MULTIMASTER

- When the bus (communication line) is free, any unit may start to transmit a message.

#### 2. MESSAGE TRANSFER

- All messages on CAN bus are sent in fixed formats.
- When the bus (communication line) is free, any unit connected to the bus may start to transmit a message.
- If two or more units start to transmit messages at the same time, these messages are prioritized using the identifier.
- The identifier does not indicate the destination of the message, but it signifies message priority for bus access.
- If two or more units start to transmit messages at the same time, bitwise (smallest-unit) arbitration is performed over the identifiers carried by the messages. The unit that has won the arbitration as carrying a higher-priority message continues to send the message while the unit that has a lower priority stops sending the message, and starts sending the message again after waiting for a while.

#### 3. SYSTEM FLEXIBILITY

- As units connected to the bus do not have unique information like an address, other units can be added to the bus without changing the software, hardware, or application of the units.

#### 4. BIT RATE

- The bit rate can be set to suit the applications of the communication network.
- The bit rate of all units connected to the same network (bus) must be uniform. Connecting units of different bit rates to the same bus will cause communication disturbances.

#### 5. ERROR SIGNALING AND COMMUNICATION RECOVERY

- Error signaling: Any unit connected to a bus can detect an error, and upon detecting an error, the unit notifies all other units of the error.
- Communication recovery: If a unit detects an error while sending a message, the unit will abort the message and keep retransmitting the message until it is successfully sent. (communication recovery)

#### 6. FAULT CONFINEMENT

- In CAN, there are two types of errors: temporary alteration of data on the bus caused by external noise or other disturbances; and permanent alteration of data on the bus caused by faulty units, failed drivers, open wire, or other failures. Causal units will be cut off from the bus to prevent such disturbances/failures from affecting other units.

## 7. CONNECTION ENVIRONMENTS

- The CAN bus accommodates connections of a number of units to it.
- There are no limitations on the number of units that can be connected to the CAN bus, however, if the bus length needs to be longer or the bit rate needs to be higher, the number of units needs to be smaller. On the other hand, if the bus length is relatively short or a relatively slower bit rate can be accepted, a greater number of units can be connected.
- As signals are distinguished with the voltage difference between the two bus lines (CAN\_High and CAN\_Low), the main lines and branch lines must be properly connected.

## 4. Fault Detection

### A: COMMUNICATION ERROR INDICATIONS

- If a fault occurs in the body integrated unit or LAN system (in any unit or the communication circuit), a communication error indication is given at the trip information display area on the combination meter.
- The indication differs by the type of fault, and related indicators such as the CHECK ENGINE light illuminate.
- If a communication error indication is given, one or more diagnostic trouble codes are stored in the body integrated unit. To read out diagnostic trouble codes, use a Subaru select monitor.
- If more than one diagnostic trouble code is stored, indication is given in the following order of priority: (1) High-speed CAN (2) Low-speed CAN (3) integrated unit (4) EGI (5) TCM (6) VDC

#### NOTE:

The indication returns to the normal trip display when the trip reset switch is pushed.

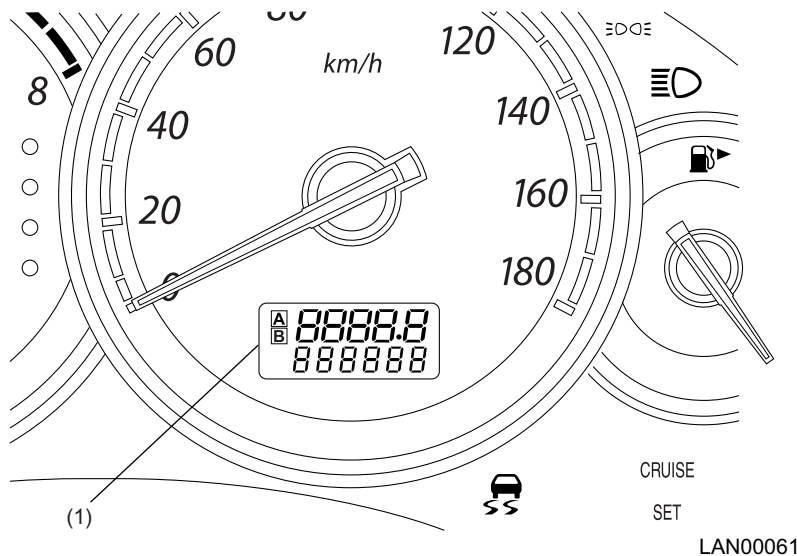

(1) Communication error indication area (trip meter)

#### CAUTION:

- Information registered in the body integrated unit must coincide with the vehicle's equipment and specifications for normal operation and diagnosis.
- If the body integrated unit is brand-new or put in factory mode, the key ring illumination blinks to indicate that equipment setting is not completed.

## Types of communication error indications

Communication error indication	Description	Location of fault
Er --	High-speed CAN and low-speed CAN failed	Abnormality is found in both the high-speed and low-speed CAN communication systems.
Er HC	High-speed CAN failed	Abnormality is found in the high-speed CAN system.
Er LC	Low-speed CAN failed	Abnormality is found in the low-speed CAN system.
Er IU	Integrated unit failed	Abnormality is found in the integrated ECM or in its related parts.
Er EG	EGI communication data abnormal	Abnormality is found in the EGI ECM or in its communication system.
Er tC	TCM communication data abnormal	Abnormality is found in the TCM ECM or in its communication system.
Er Ab	ABS/VDC communication data abnormal	Abnormality is found in the ABSCM/VDCCM & H/U unit or in its communication system.

## **B: SUBARU SELECT MONITOR**

### **1. READING DIAGNOSTIC TROUBLE CODES**

- Diagnostic trouble codes can be read with a Subaru select monitor set in its body integrated unit mode.

### **2. READING CURRENT DATA**

- Use a Subaru select monitor to read analog and digital data. (Confirm necessary items when customizing.)

### **3. MEMORY CLEAR MODE**

- Use a Subaru select monitor to erase diagnostic trouble codes.

### **4. CUSTOMIZING (SETTING FUNCTIONS)**

- Use a Subaru select monitor to perform detailed setting of body control related functions.
- When replacing immobilizer related components, registration of the immobilizer may be necessary.

(Refer to the immobilizer registering manual.)

#### **CAUTION:**

When customizing, do not change the factory mode resetting function to factory mode. If you do this, settings stored in the body integrated unit will be reset to initial values and the unit will not operate normally. In this case, perform registration of the body integrated unit from the very beginning.

# FAULT DETECTION

LAN SYSTEM

---

**MEMO**