

# **WHEEL AND TIRE SYSTEM**

# General Description

## WHEEL AND TIRE SYSTEM

### 1. General Description

#### A: SPECIFICATION

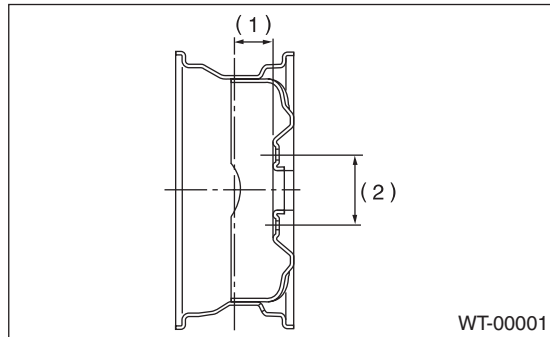

(1) Offset

(2) P.C.D.

Model	Tire size	Wheel size	Offset mm (in)	P.C.D. mm (in)	Tire inflation pressure kPa (kgf/cm <sup>2</sup> , psi)	
					Front wheel	Rear wheel
2.5l	P205/55R16 89V	16 × 6 <sup>1</sup> / <sub>2</sub> JJ	55 (2.17)	100 (3.94)	230 (2.3, 33)	220 (2.2, 32)
WRX, OUTBACK	P205/50 R17 88V	17 × 7JJ				
"T-type" Tire	T125/70D17 98M	17 × 4T	30 (1.18)		420 (4.2, 60)	

#### NOTE:

"T-type" tire for temporary use is equipped as a spare tire.

#### 1. SERVICE DATA

Part	Axial runout	Radial runout
Steel wheel	1.5 mm (0.059 in)	
Aluminum wheel	1.0 mm (0.039 in)	

# General Description

## WHEEL AND TIRE SYSTEM

### 2. ADJUSTING PARTS

Wheel balancing	Standard:	Service limit
Dynamic unbalance	5 g (0.18 oz) or less	

Balance weight part number (Knock-on type weight for steel wheels)	Weight
28101TC000	5 g (0.18 oz)
28101SA060	10 g (0.35 oz)
28101SA070	15 g (0.53 oz)
28101SA080	20 g (0.71 oz)
28101SA090	25 g (0.88 oz)
28101SA160	30 g (1.06 oz)
28101SA170	35 g (1.23 oz)
28101SA180	40 g (1.41 oz)
28101SA190	45 g (1.59 oz)
28101SA200	50 g (1.76 oz)
28101SA210	55 g (1.94 oz)
28101SA220	60 g (2.12 oz)

Balance weight part number (Knock-on type weight for aluminum wheel)	Weight
28101SA000	5 g (0.18 oz)
28101SA010	10 g (0.35 oz)
28101SA020	15 g (0.53 oz)
28101SA030	20 g (0.71 oz)
28101SA040	25 g (0.88 oz)
28101SA100	30 g (1.06 oz)
28101SA110	35 g (1.23 oz)
28101SA120	40 g (1.41 oz)
28101SA130	45 g (1.59 oz)
28101SA140	50 g (1.76 oz)
—	55 g (1.94 oz)
28101SA150	60 g (2.12 oz)

Balance weight part number (Adhesive type weight for aluminum wheel)	Weight
28101AG002	5 g (0.18 oz)
28101AG012	7.5 g (0.26 oz)
28101AG022	10 g (0.35 oz)
28101AG032	12.5 g (0.44 oz)
28101AG042	15 g (0.53 oz)
28101AG052	17.5 g (0.62 oz)
28101AG062	20 g (0.71 oz)
28101AG072	22.5 g (0.79 oz)
28101AG082	25 g (0.88 oz)
28101AG092	27.5 g (0.97 oz)
28101AG102	30 g (1.06 oz)
28101AG112	32.5 g (1.15 oz)
28101AG122	35 g (1.23 oz)
28101AG132	37.5 g (1.32 oz)
28101AG142	40 g (1.41 oz)
28101AG152	42.5 g (1.50 oz)
28101AG162	45 g (1.59 oz)
28101AG172	47.5 g (1.68 oz)
28101AG182	50 g (1.76 oz)
28101AG192	52.5 g (1.85 oz)
28101AG202	55 g (1.94 oz)
28101AG212	57.5 g (2.03 oz)
28101AG222	60 g (2.12 oz)
28101AG232	62.5 g (2.20 oz)
28101AG242	65 g (2.29 oz)
28101AG252	67.5 g (2.38 oz)
28101AG262	70 g (2.47 oz)
28101AG272	72.5 g (2.56 oz)
28101AG282	75 g (2.65 oz)
28101AG292	77.5 g (2.73 oz)
28101AG302	80 g (2.82 oz)
28101AG312	82.5 g (2.91 oz)
28101AG322	85 g (3.00 oz)
28101AG332	87.5 g (3.09 oz)
28101AG342	90 g (3.17 oz)
28101AG352	92.5 g (3.26 oz)
28101AG362	95 g (3.35 oz)
28101AG372	97.5 g (3.44 oz)
28101AG382	100 g (3.53 oz)
28101SA300	102.5 g (3.62 oz)
28101SA310	105 g (3.70 oz)
28101SA320	107.5 g (3.79 oz)
28101SA330	110 g (3.88 oz)
28101SA340	112.5 g (3.97 oz)
28101SA350	115 g (4.06 oz)
28101SA360	117.5 g (4.14 oz)
28101SA370	120 g (4.23 oz)

# General Description

## WHEEL AND TIRE SYSTEM

### B: COMPONENT

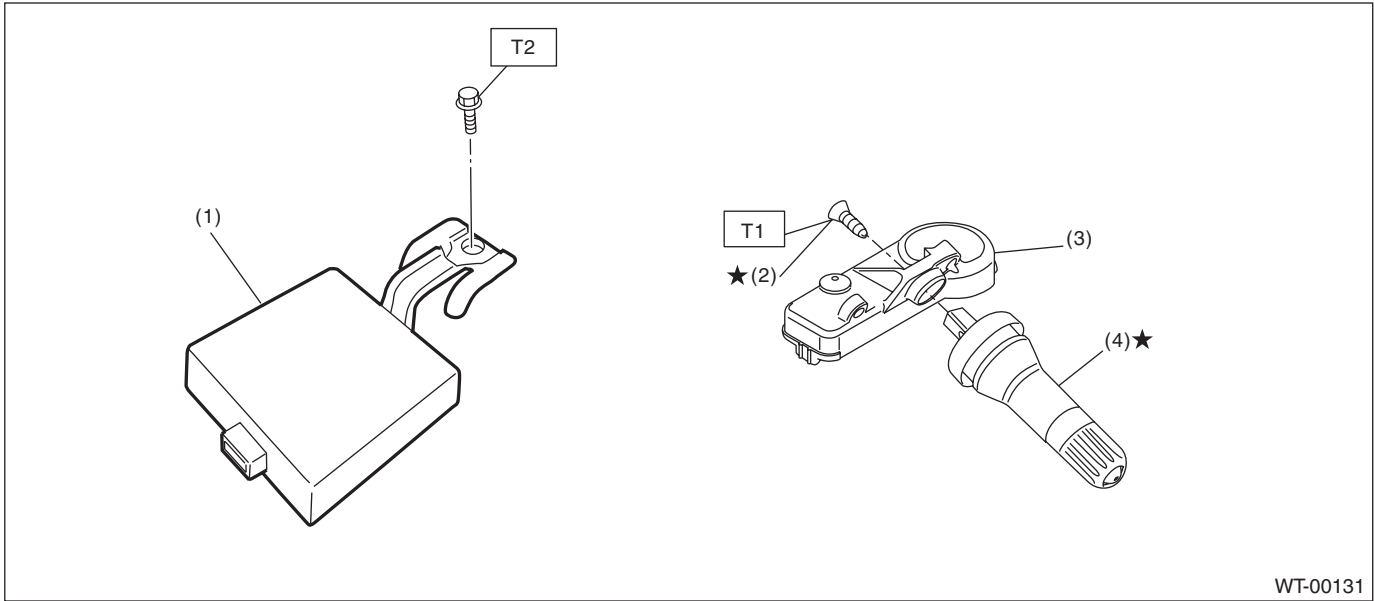

WT-00131

- (1) Tire pressure monitoring control module  
(2) Screw  
(3) Transmitter (Snap in type)  
(4) Valve

**Tightening torque:N-m (kgf-m, ft-lb)**  
**T1: 1.4 (0.14, 1)**  
**T2: 7.5 (0.76, 5.5)**

### C: PREPARATION TOOL

#### 1. GENERAL TOOL

TOOL NAME	REMARKS
Air pressure gauge	Used for measuring tire air pressure.
Dial gauge	Used for measuring wheel runout.
Wheel balancer	Used for adjusting wheel balance.

## 2. Tire

### A: INSPECTION

- 1) Take stones, glass, nails etc. out of the tread groove.
- 2) Replace tires in the following cases.

#### CAUTION:

- When replacing a tire, make sure to use only tires of the same size, construction and load range as originally installed.
- When the direction of tire rotation is specified, be careful not to install the tire to the wheel in the wrong direction.
- Use a tire changer when removing the tire from the wheel.
- On models equipped with tire pressure monitoring systems, do not use the bead breaker in a 90° area centered on the transmitter to prevent damaging the transmitter.

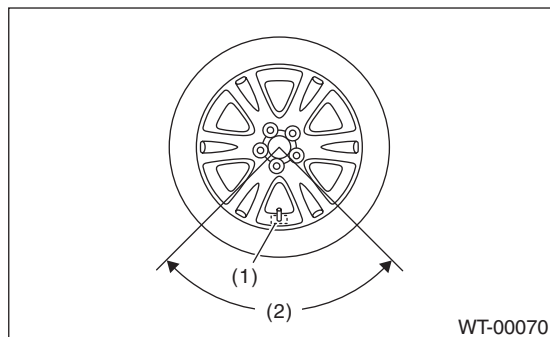

- (1) Transmitter
- (2) 90°(use of a bead breaker is prohibited in this area.)

- To prevent damaging the transmitter, set the tire changer boom in the position as shown in the figure.

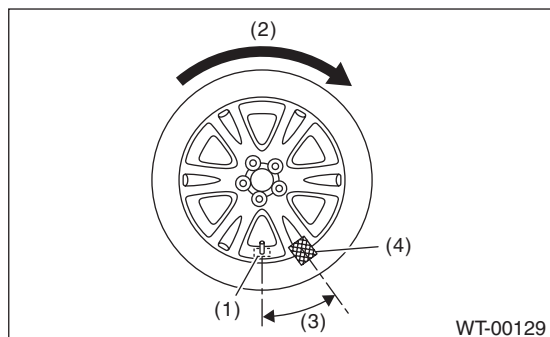

- (1) Transmitter
- (2) Direction of turn table rotation
- (3) 30°
- (4) Tire changer boom

- (1) If large cracks on side wall, damage or cracks on the tread is found.
- (2) When the “tread wear indicator” appears as a solid band across the tread.

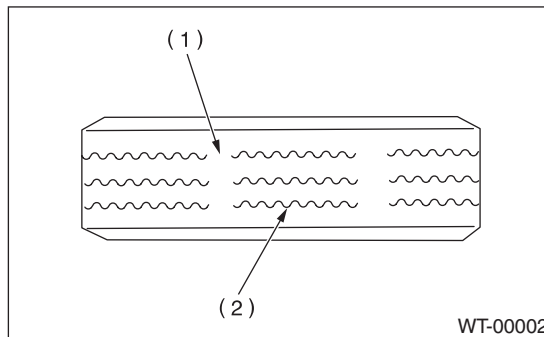

- (1) Tread wear indicator
- (2) Tire tread

- 3) When a crack on tire valve is found, replace the tire valve.

### 1. TIRE ROTATION

Rotate tires periodically (12,500 km/7,500 miles) as shown in the figure, in order to prevent them from uneven wear and to prolong their life.

- When the direction of tire rotation is not specified

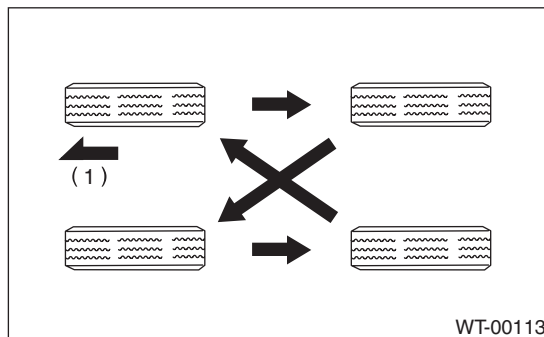

- (1) Front

- With instruction for the direction of tire rotation

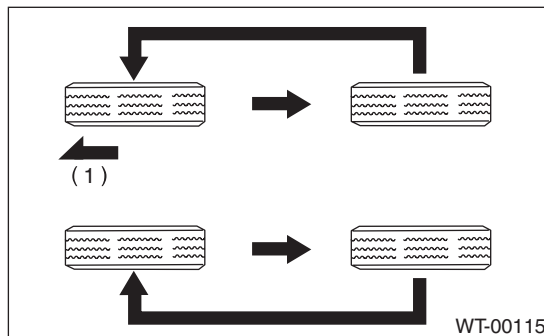

- (1) Front

#### NOTE:

Vehicles equipped with tire pressure monitoring systems will require re-registration of transmitter ID. <Ref. to TPM(diag)-10, REGISTER TRANSMITTER ID, OPERATION, Subaru Select Monitor.>

### 3. Steel Wheel

#### A: REMOVAL

- 1) Apply the parking brake, and position select lever or shift lever to "P" range (AT model) or "1st gear" (MT model).
- 2) Set the shop jacks or a lift to the specified points, and support the vehicle with its wheels slightly contacting the floor.
- 3) Loosen the wheel nuts.
- 4) Raise the vehicle until its tires are off the ground using the jack or a lift.
- 5) Remove the wheel nuts and wheels.

#### NOTE:

- When removing the wheels, be careful not to damage the hub bolts.
- Place the wheels with their outer sides facing upward to prevent wheels from being damaged.

#### B: INSTALLATION

- 1) Remove dirt from the mating surface of the wheel and brake rotor.
- 2) Attach the wheel to the hub by aligning the wheel bolt holes with the hub bolts.
- 3) Temporarily attach the wheel nuts to the hub bolts. (In the case of aluminum wheels, use SUBARU genuine wheel nuts for aluminum wheels.)
- 4) Tighten the nuts by hand, making sure the wheel hub hole is aligned correctly to the guide portion of hub.
- 5) Tighten the wheel nuts in a diagonal selection to the specified torque. Use a wheel nut wrench.

#### **Wheel nut tightening torque:**

**100 N·m (10.2 kgf·m, 73.8 ft·lb)**

#### CAUTION:

- **Tighten the wheel nuts in two or three steps by gradually increasing the torque on opposing nuts, until they reach the specified torque. For drum brake model, excess tightening of wheel nuts may cause wheels to "judder".**
  - **Do not push the wrench by foot. Always use both hands when tightening the nuts.**
  - **Make sure the bolt, nut and the nut seating surface of the wheel are free from oil.**
- 6) If a wheel is removed for replacement or for repair of a puncture, retighten the wheel nuts to the specified torque after driving 1,000 km (600 miles).

#### C: INSPECTION

- 1) Deformation or damage to the rim may cause air leakage. Check the rim flange for deformation, cracks or damage, and repair or replace as necessary.
- 2) Jack-up the vehicle until tires clear the floor.
- 3) Slowly rotate the wheel to check rim "runout" using a dial gauge.

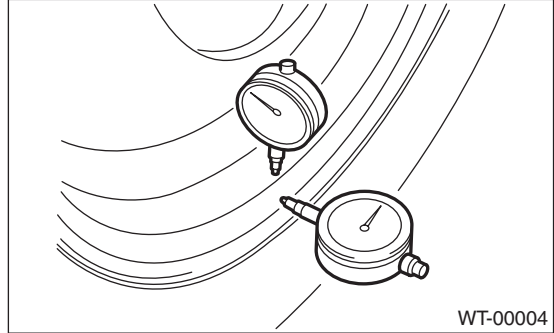

Axial runout limit	Radial runout limit
1.5 mm (0.059 in)	

- 4) If the rim runout exceeds specifications, replace the wheel.

## 4. Aluminum Wheel

### A: REMOVAL

Refer to “Steel Wheels” for removal procedure of aluminum wheels. <Ref. to WT-6, REMOVAL, Steel Wheel.>

### B: INSTALLATION

Refer to “Steel Wheels” for installation procedure of aluminum wheels. <Ref. to WT-6, INSTALLATION, Steel Wheel.>

### C: INSPECTION

Refer to “Steel Wheels” for inspection procedure of aluminum wheels. <Ref. to WT-6, INSPECTION, Steel Wheel.>

#### *Rim runout*

Axial runout limit	Radial runout limit
1.0 mm (0.039 in)	

### D: CAUTION

Aluminum wheels are easily scratched. To maintain their appearance and safety, be careful of the following:

- 1) Be careful not to damage the aluminum wheels during removal, installation, wheel balancing, etc. After removing aluminum wheels, place them on a rubber mat etc.
- 2) When washing the aluminum wheel, use neutral synthetic detergent and water. Avoid using cleansers containing abrasives, hard brushes or an automatic car washer.

# Wheel Balancing

## WHEEL AND TIRE SYSTEM

### 5. Wheel Balancing

#### A: ADJUSTMENT

##### NOTE:

Change the setting of wheel balancer to adhesive type weight if adhesive type weight is adopted.

1) Remove the balance weights.

##### CAUTION:

- Be careful not to damage the wheel.
- Completely remove the double-sided tape of the adhesive weight from the wheel.

2) Using the wheel balancer, measure wheel balance.

3) Select a weight close to the value measured by wheel balancer.

##### CAUTION:

Use SUBARU genuine balance weights.

Balance weight part number (Knock-on type weight for steel wheels)	Weight
28101TC000	5 g (0.18 oz)
28101SA060	10 g (0.35 oz)
28101SA070	15 g (0.53 oz)
28101SA080	20 g (0.71 oz)
28101SA090	25 g (0.88 oz)
28101SA160	30 g (1.06 oz)
28101SA170	35 g (1.23 oz)
28101SA180	40 g (1.41 oz)
28101SA190	45 g (1.59 oz)
28101SA200	50 g (1.76 oz)
28101SA210	55 g (1.94 oz)
28101SA220	60 g (2.12 oz)

Balance weight part number (Knock-on type weight for aluminum wheel)	Weight
28101SA000	5 g (0.18 oz)
28101SA010	10 g (0.35 oz)
28101SA020	15 g (0.53 oz)
28101SA030	20 g (0.71 oz)
28101SA040	25 g (0.88 oz)
28101SA100	30 g (1.06 oz)
28101SA110	35 g (1.23 oz)
28101SA120	40 g (1.41 oz)
28101SA130	45 g (1.59 oz)
28101SA140	50 g (1.76 oz)
—	55 g (1.94 oz)
28101SA150	60 g (2.12 oz)

Balance weight part number (Adhesive type weight for aluminum wheel)	Weight
28101AG002	5 g (0.18 oz)
28101AG012	7.5 g (0.26 oz)
28101AG022	10 g (0.35 oz)
28101AG032	12.5 g (0.44 oz)
28101AG042	15 g (0.53 oz)
28101AG052	17.5 g (0.62 oz)
28101AG062	20 g (0.71 oz)
28101AG072	22.5 g (0.79 oz)
28101AG082	25 g (0.88 oz)
28101AG092	27.5 g (0.97 oz)
28101AG102	30 g (1.06 oz)
28101AG112	32.5 g (1.15 oz)
28101AG122	35 g (1.23 oz)
28101AG132	37.5 g (1.32 oz)
28101AG142	40 g (1.41 oz)
28101AG152	42.5 g (1.50 oz)
28101AG162	45 g (1.59 oz)
28101AG172	47.5 g (1.68 oz)
28101AG182	50 g (1.76 oz)
28101AG192	52.5 g (1.85 oz)
28101AG202	55 g (1.94 oz)
28101AG212	57.5 g (2.03 oz)
28101AG222	60 g (2.12 oz)
28101AG232	62.5 g (2.20 oz)
28101AG242	65 g (2.29 oz)
28101AG252	67.5 g (2.38 oz)
28101AG262	70 g (2.47 oz)
28101AG272	72.5 g (2.56 oz)
28101AG282	75 g (2.65 oz)
28101AG292	77.5 g (2.73 oz)
28101AG302	80 g (2.82 oz)
28101AG312	82.5 g (2.91 oz)
28101AG322	85 g (3.00 oz)
28101AG332	87.5 g (3.09 oz)
28101AG342	90 g (3.17 oz)
28101AG352	92.5 g (3.26 oz)
28101AG362	95 g (3.35 oz)
28101AG372	97.5 g (3.44 oz)
28101AG382	100 g (3.53 oz)
28101SA300	102.5 g (3.62 oz)
28101SA310	105 g (3.70 oz)
28101SA320	107.5 g (3.79 oz)
28101SA330	110 g (3.88 oz)
28101SA340	112.5 g (3.97 oz)
28101SA350	115 g (4.06 oz)
28101SA360	117.5 g (4.14 oz)
28101SA370	120 g (4.23 oz)



4) Install the selected weight to the point designated by the wheel balancer.

**CAUTION:**

- **Degrease the wheel surface where the adhesive type weight will be applied.**
- **Press the adhesive type weight by 25 N (2.5 kgf, 5.6 lbf) or more per 5 g (0.18 oz) for 2 seconds or more and attain full adhesion.**
- **Total application of the adhesive type weight should be 120 g (4.23 oz) or less.**

5) Using the wheel balancer, measure the wheel balance again. Check that wheel balance is correctly adjusted.

**B: INSPECTION**

1) When a tire is replaced or worn, proper wheel balance may be lost. Check the tire dynamic balance and repair if necessary.

2) When checking the dynamic balance, use the wheel balancer. Insert the balance weights into the top and the rear side of rim.

3) With some types of balancer, wheels may be damaged. When adjusting the wheel balance, use a proper balancer.

4) Use Subaru genuine balance weights.

**NOTE:**

- Balance weights are not available in 55 g (1.94 oz) size for aluminum wheels.
- Balance weights can be used for any 15 to 18-inch wheels.

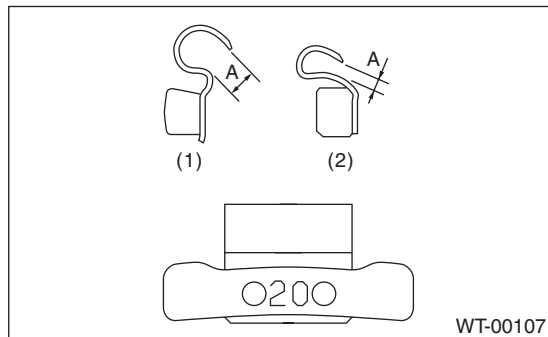

- (1) Knock-on type weight for aluminum wheel
- (2) Knock-on type weight for steel wheel

**Service limit A:**

**Knock-on type weight for steel wheel:**

**2.0 mm (0.079 in)**

**Knock-on type weight for aluminum wheel:**

**5.0 mm (0.197 in)**

### 6. “T-type” Tire

#### A: NOTE

“T-type” tire for temporary use is prepared as a spare tire.

#### CAUTION:

- Do not use tire chains for “T-type Tire”. Because tire size is small, tire chains can not be installed and will damage the vehicle and tires.
- Do not drive at a speed greater than 80 km/h (50 MPH).
- Drive the vehicle as slowly as possible and avoid bumps on the road.

#### B: REPLACEMENT

Refer to “Removal/Installation of Steel Wheels” for removal and installation procedures of the “T-type” tire. <Ref. to WT-6, Steel Wheel.>

#### CAUTION:

The “T-type” tire is only for temporary use. Replace with a conventional tire as soon as possible.

#### C: INSPECTION

- 1) Check the tire air pressure.

#### *Specifications:*

***420 kPa (4.2 kgf/cm<sup>2</sup>, 60 psi)***

- 2) Take stones, glass, nails etc. out of the tread groove.
- 3) Check the tires for deformation, cracks, partial wear, or wear.

## 7. Full Wheel Cap

### A: REMOVAL

Insert a remover into the notch located diagonally to the valve hole, and remove the cap by prying the remover to the tire side.

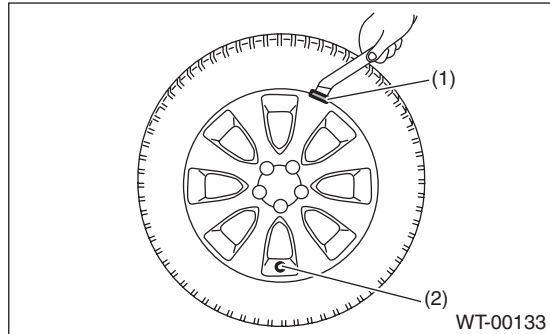

- (1) Cutout portion
- (2) Valve hole

### B: INSTALLATION

- 1) Align the valve with the valve hole in the hubcap.
- 2) Install the hubcap by tapping it in the order from (1) to (3) described in the figure.

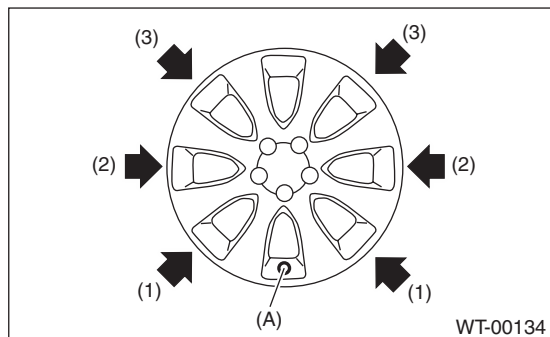

- (A) Valve hole

### C: INSPECTION

Check the hubcap for damage.

# Tire Pressure Monitoring System

## WHEEL AND TIRE SYSTEM

### 8. Tire Pressure Monitoring System

#### A: REMOVAL

##### 1. TRANSMITTER (SNAP IN TYPE)

- 1) Remove the wheels from the vehicle. <Ref. to WT-6, REMOVAL, Steel Wheel.>
- 2) Remove the tires from wheels.

#### CAUTION:

Use a tire changer when removing the tire from the wheel.

- 3) Loosen the screw to remove the transmitter from the valve stem.

#### NOTE:

Replace the valve and screw with a new part when reusing transmitter.

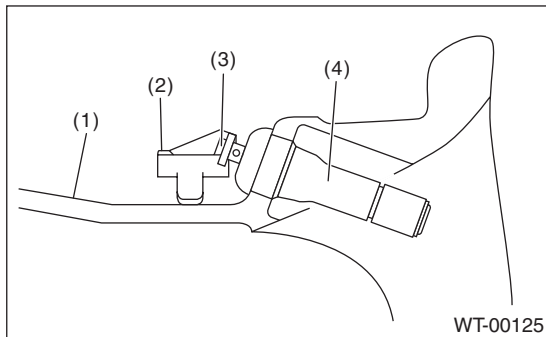

- (1) Wheel
- (2) Transmitter
- (3) Screw
- (4) Valve

- 4) Remove the valve from the wheel.

##### 2. TIRE PRESSURE MONITORING CONTROL MODULE

- 1) Remove the canister. <Ref. to EC(H4SO)-5, REMOVAL, Canister.>
- 2) Remove the connector to remove tire pressure monitoring control module.

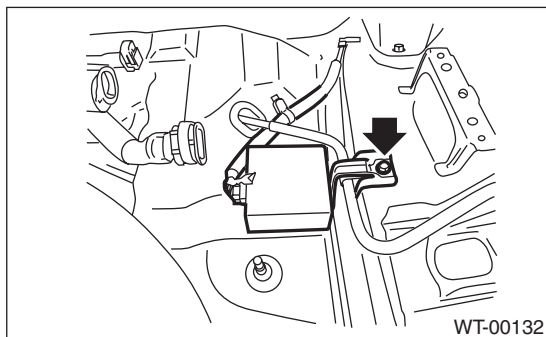

#### B: INSTALLATION

##### 1. TRANSMITTER (SNAP IN TYPE)

#### CAUTION:

Use the new transmitter assembly or replace the new valve and screw, when installing.

- 1) Replace the valve and screw with a new part when reusing transmitter.

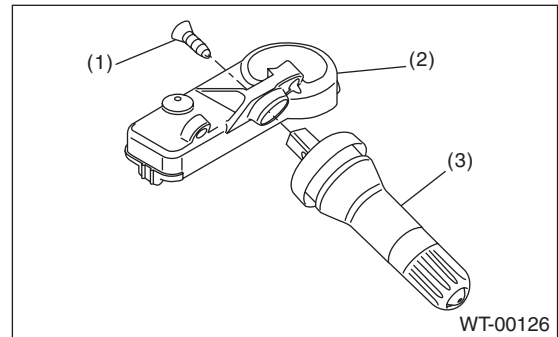

- (1) Screw
- (2) Transmitter
- (3) Valve

#### Tightening torque:

**1.4 N·m (0.14 kgf·m, 1 ft·lb)**

- 2) Install the transmitter to the wheel by aligning it with valve hole.

#### NOTE:

When using the jig that pulls the valve cap by hooking its neck part, use another short-type cap.

- 3) Install the tires to wheels.

#### CAUTION:

- Use a tire changer when installing tire to wheel.
- To prevent damaging the transmitter, set the tire changer boom in the position as shown in the figure.

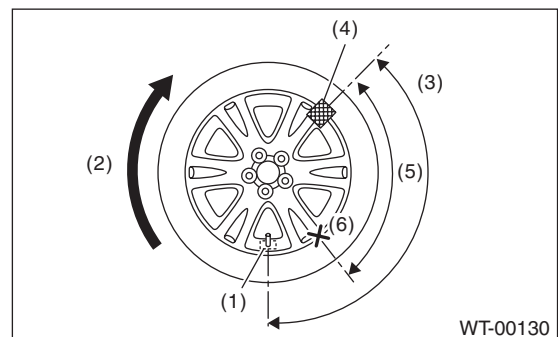

- (1) Transmitter
- (2) Direction of turn table rotation
- (3) 135°
- (4) Tire changer boom
- (5) 90°
- (6) Starting point for fitting the bead to the rim

4) Install the wheels to vehicle. <Ref. to WT-6, INSTALLATION, Steel Wheel.>

5) Register the transmitter ID to the tire pressure monitoring control module. <Ref. to TPM(diag)-10, REGISTER TRANSMITTER ID, OPERATION, Subaru Select Monitor.>

## **2. TIRE PRESSURE MONITORING CONTROL MODULE**

Install in the reverse order of removal.

### ***Tightening torque:***

***7.5 N·m (0.76 kgf-m, 5.5 ft-lb)***

## **C: ADJUSTMENT**

Re-register the transmitter ID when transmitter has been replaced. <Ref. to TPM(diag)-10, REGISTER TRANSMITTER ID, OPERATION, Subaru Select Monitor.>

# General Diagnostic Table

## WHEEL AND TIRE SYSTEM

### 9. General Diagnostic Table

#### A: INSPECTION

Symptoms	Possible cause	Corrective action
Wheel is out of balance.	Improperly inflated tire.	Adjust the tire pressure.
	Uneven wear	Check the tire referring to Abnormal tire wear in this table, carry out the procedure and replace the tire.
	Front wheel alignment	Check the front wheel alignment. <Ref. to FS-6, INSPECTION, Wheel Alignment.>
	Rear wheel alignment	Check the rear wheel alignment. <Ref. to RS-7, INSPECTION, Wheel Alignment.>
	Front strut	Check the front strut. <Ref. to FS-23, INSPECTION, Front Strut.>
	Rear shock absorber	Check the rear shock absorber. <Ref. to RS-12, INSPECTION, Rear Shock Absorber.>
	Front axle	Check the front axle. <Ref. to DS-16, INSPECTION, Front Axle.>
	Front hub unit bearing	Check the front hub unit bearing. <Ref. to DS-18, INSPECTION, Front Hub Unit Bearing.>
	Rear hub unit bearing	Check the rear hub unit bearing. <Ref. to DS-24, INSPECTION, Rear Hub Unit Bearing.>
Vehicle is abnormally out of balance.	Improperly inflated tire.	Adjust the tire pressure.
	Uneven wear	Check the tire referring to Abnormal tire wear in this table, carry out the procedure and replace the tire.
	Front stabilizer	Inspect the front stabilizer. <Ref. to FS-15, INSPECTION, Front Stabilizer.>
	Front wheel alignment	Check the front wheel alignment. <Ref. to FS-6, INSPECTION, Wheel Alignment.>
	Rear wheel alignment	Check the rear wheel alignment. <Ref. to RS-7, INSPECTION, Wheel Alignment.>
Abnormal wheel vibration	Improperly inflated tire.	Adjust the tire pressure.
	Uneven wear	Check the tire referring to Abnormal tire wear in this table, carry out the procedure and replace the tire.
	Improper wheel balancing	Check the wheel balance. <Ref. to WT-8, ADJUSTMENT, Wheel Balancing.>
	Front axle	Check the front axle. <Ref. to DS-16, INSPECTION, Front Axle.>
	Front hub unit bearing	Check the front hub unit bearing. <Ref. to DS-18, INSPECTION, Front Hub Unit Bearing.>
	Rear hub unit bearing	Check the rear hub unit bearing. <Ref. to DS-24, INSPECTION, Rear Hub Unit Bearing.>
Abnormal tire wear	Improperly inflated tire.	Adjust the tire pressure.
	Improper wheel balancing	Check the wheel balance. <Ref. to WT-8, ADJUSTMENT, Wheel Balancing.>
	Front wheel alignment	Check the front wheel alignment. <Ref. to FS-6, INSPECTION, Wheel Alignment.>
	Rear wheel alignment	Check the rear wheel alignment. <Ref. to RS-7, INSPECTION, Wheel Alignment.>